

| REVISIONS |          |        |     |      |
|-----------|----------|--------|-----|------|
| SYM       | DATE     | EO NO. | BY  | APPR |
| A         | 1/16/18  | 44820  | DMR | TH   |
| B         | 9/17/18  | 45169  | DMR | TH   |
| C         | 12/19/18 | 45282  | DMR | TH   |
| D         | 12/18/19 | 45711  | DMR | TH   |
| E         | 4/27/20  | 45833  | DMR | TH   |

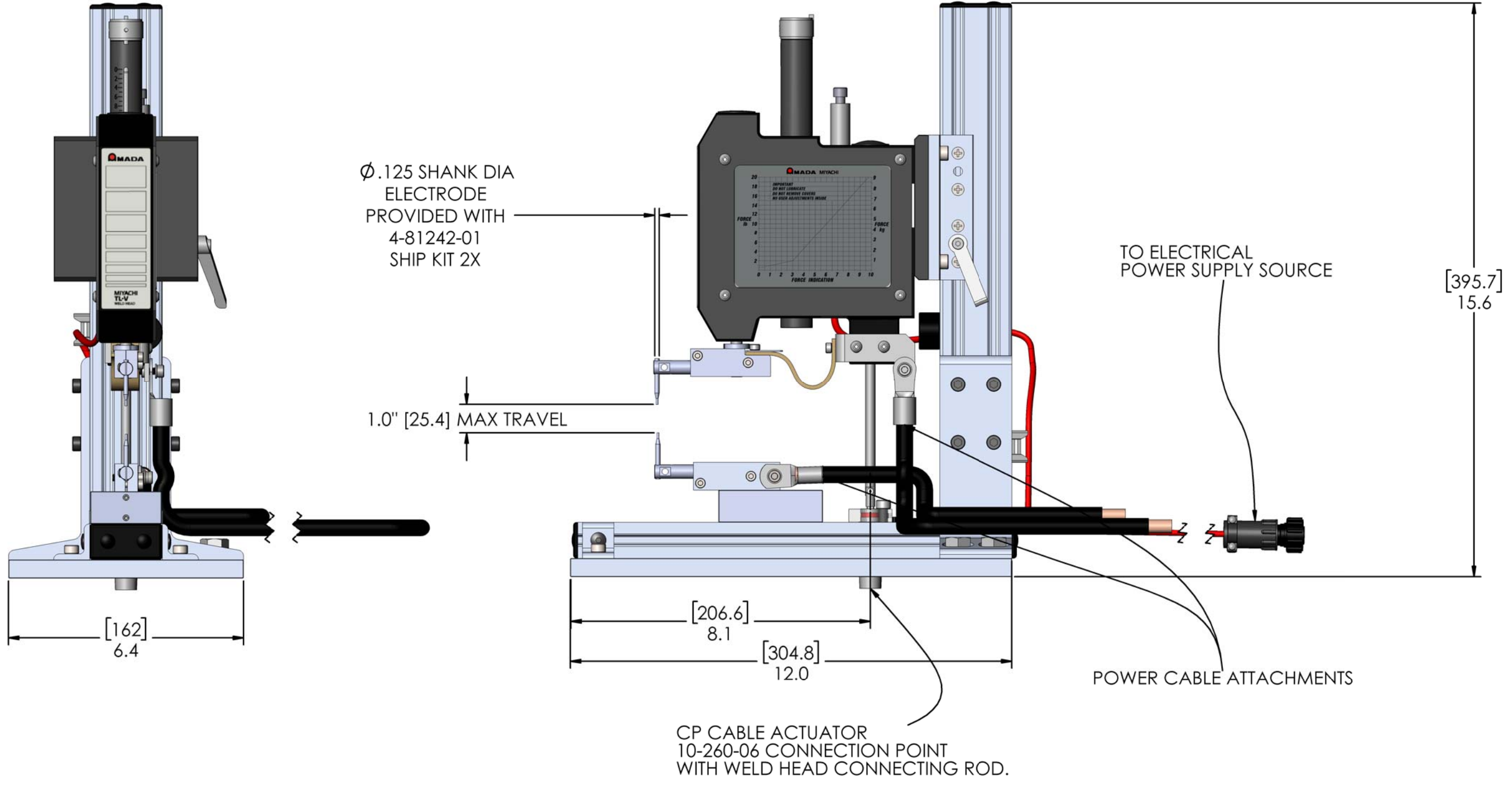

Ø.125 SHANK DIA  
ELECTRODE  
PROVIDED WITH  
4-81242-01  
SHIP KIT 2X

TO ELECTRICAL  
POWER SUPPLY SOURCE

1.0" [25.4] MAX TRAVEL

[395.7]  
15.6

[206.6]  
8.1  
[304.8]  
12.0

POWER CABLE ATTACHMENTS

CP CABLE ACTUATOR  
10-260-06 CONNECTION POINT  
WITH WELD HEAD CONNECTING ROD.

1. REFER TO 4-40802-01 TEMPLATE MOUNTING DRAWING  
FOR DRILL HOLE MOUNTING DETAILS.

MODEL TL-V080B-F SINGLE HEAD OPPOSED ELECTRODE  
WELD HEAD, MANUAL ACTUATION

PN 4-40854-01

NOTES: UNLESS OTHERWISE SPECIFIED

|                                                                                               |           |                                          |                                               |               |                |
|-----------------------------------------------------------------------------------------------|-----------|------------------------------------------|-----------------------------------------------|---------------|----------------|
| UNLESS OTHERWISE SPECIFIED<br>DIMENSIONS ARE IN INCHES/<br>DIMENSIONAL TOLERANCES             |           | MATERIAL: STK NO.                        |                                               | DRAWN: DAVE R | DATE: 11/22/17 |
| INCHES: .XX ± .01<br>.XXX ± .005<br>FRACT: 1/64                                               |           | MM: .X ± .3<br>.XX ± .13                 |                                               | ENGR:         | DATE:          |
| ANGLES: ± 1/4°<br>SURFACE ROUGHNESS: 125 MAX<br>BREAK ALL SHARP EDGES TO<br>RADIUS (OR EQUIV) |           | FINISH:                                  |                                               | CHKD:         | DATE:          |
| ALL INTERNAL RADI<br>PART TO BE FREE OF BURRS<br>CONCENTRICITY: TIR<br>REMOVE MILL SCALE      |           | APPR: MATT G                             |                                               | APPR:         | DATE: 11/22/17 |
| 2-360-01                                                                                      |           | AMADA WELD TECH INC. MONROVIA CALIFORNIA |                                               | RELEASE EO    | SCALE:         |
| MODEL                                                                                         | NEXT ASSY | REQD PER UNIT                            | TITLE                                         | SIZE          | DWG NO.        |
|                                                                                               |           |                                          | INSTALLATION DRAWING,<br>TL-V080B-F WELD HEAD | D             | 4-40854        |
|                                                                                               |           |                                          |                                               | SHEET         | 1 OF 1         |
|                                                                                               |           |                                          |                                               | REV           | E              |