

REVISIONS				
SYM	DATE	EO NO.	BY	APPR
A	11/30/17	44820	DMR	TH
B	9/17/18	45169	DMR	TH
C	12/18/19	45711	DMR	TH
D	4/27/20	45833	DMR	TH

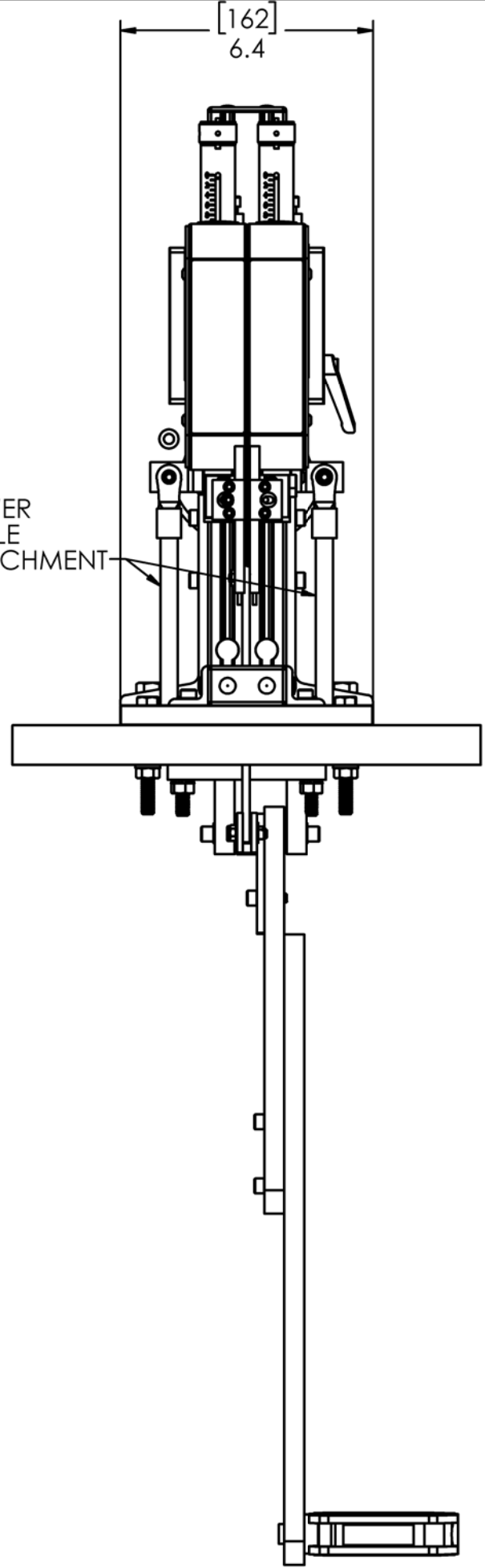
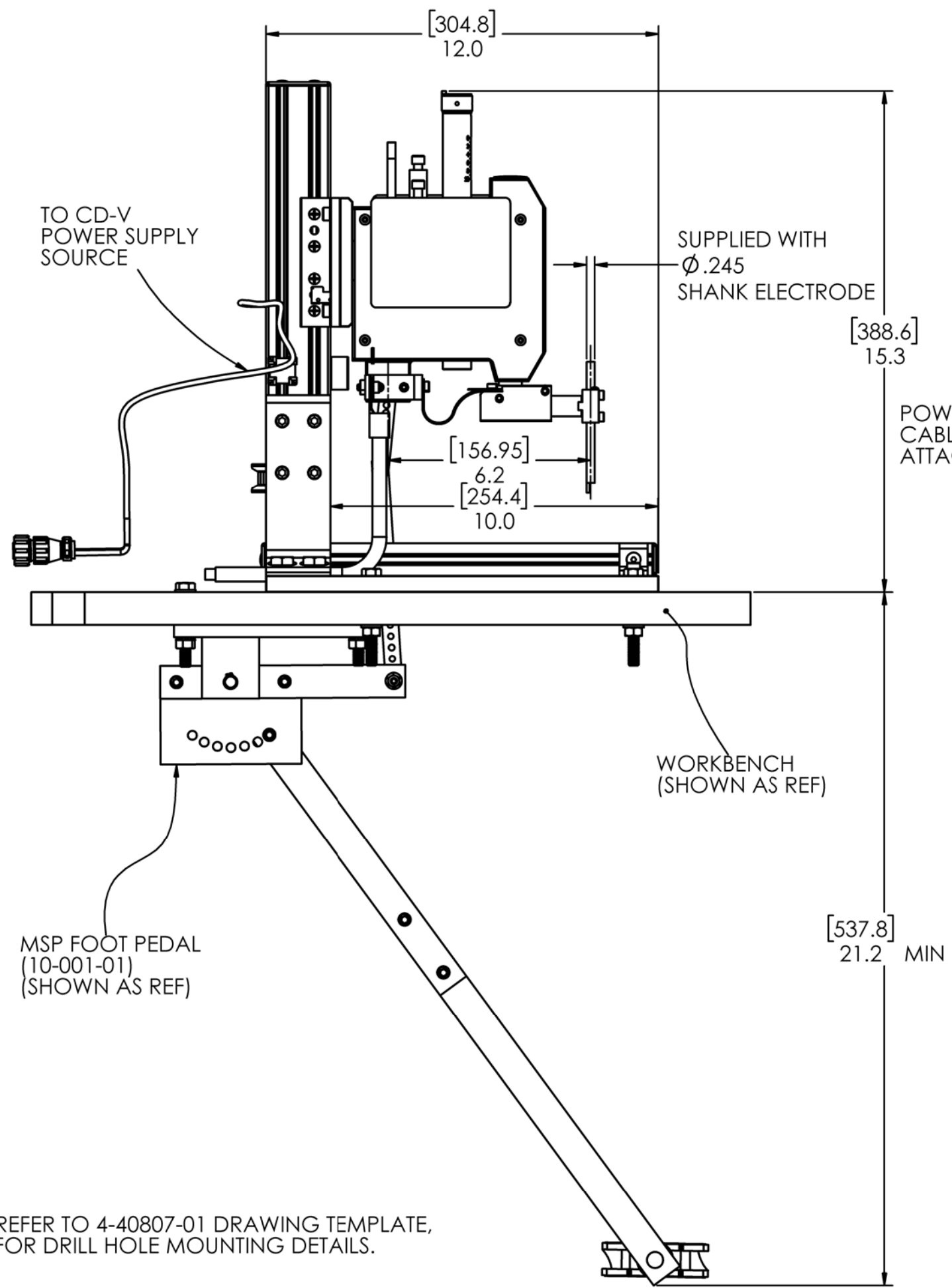

2-360-02
 TL-V088B-F DUAL HEAD PARALLEL GAP
 ELECTRODE, MANUAL ACTUATION.

PN 4-40852-01

1. REFER TO 4-40807-01 DRAWING TEMPLATE,
 FOR DRILL HOLE MOUNTING DETAILS.

NOTES: UNLESS OTHERWISE SPECIFIED

UNLESS OTHERWISE SPECIFIED DIMENSIONAL TOLERANCES		MATERIAL: STK NO.	DRAWN: DAVE R	DATE: 11/21/17
INCHES: .XX ± .01 .XXX ± .005 FRACT ± 1/64		FINISH:	ENGR:	DATE:
MM: X ± .3 .XX ± .13		AMADA WELD TECH INC. MONROVIA CALIFORNIA	CHKD:	DATE:
ANGLES ± 1/4°		AMADA WELD TECH INC. MONROVIA CALIFORNIA	APPR: MATT G	DATE: 11/21/17
SURFACE ROUGHNESS: 125 MAX BREAK ALL SHARP EDGES TO RADIUS (OR EQUIV)		TITLE: INSTALLATION DRAWING, TL-V088B-F WELD HEAD	RELEASE: EO	SCALE:
ALL INTERNAL RADII PART TO BE FREE OF BURRS CONCENTRICITY REMOVE MILL SCALE		SIZE: D	DWG NO.: 4-40852	REV: D
2-360-02	MODEL	NEXT ASSY	REQD PER UNIT	SHEET 1 OF 1