

REVISIONS				
SYM	DATE	E O NO.	BY	APPR
A	05/12/06	20764	CZ	G.B.
B	05/28/09	31368	VWW	VWW
C	07/12/11	41250	VWW	VWW
D	SKIPPED DUE TO JDE INPUT ERROR			
E	02/07/12	41750	VWW	VWW
F	09/26/16	44408	D. VEGA	T. HOUY
G	07/09/18	45103	G.A.M.	T.HOUY
H	06/02/19	45505	G.A.M.	T.HOUY
J	06/10/20	45913	D.A.V	T.HOUY

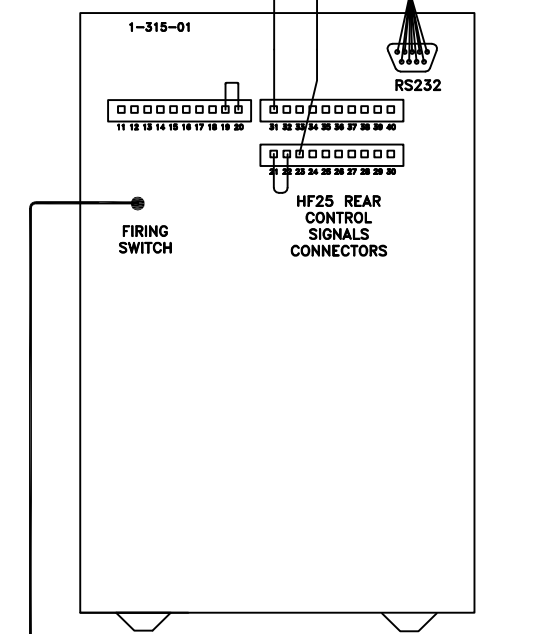
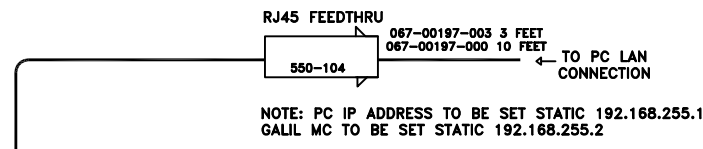
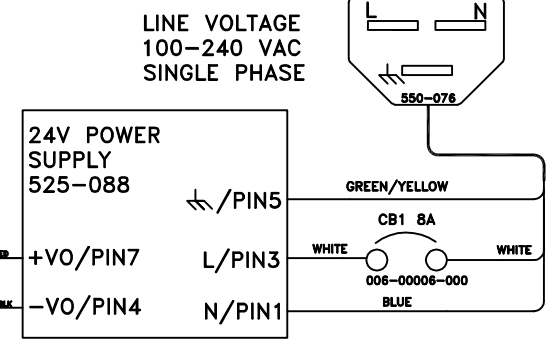
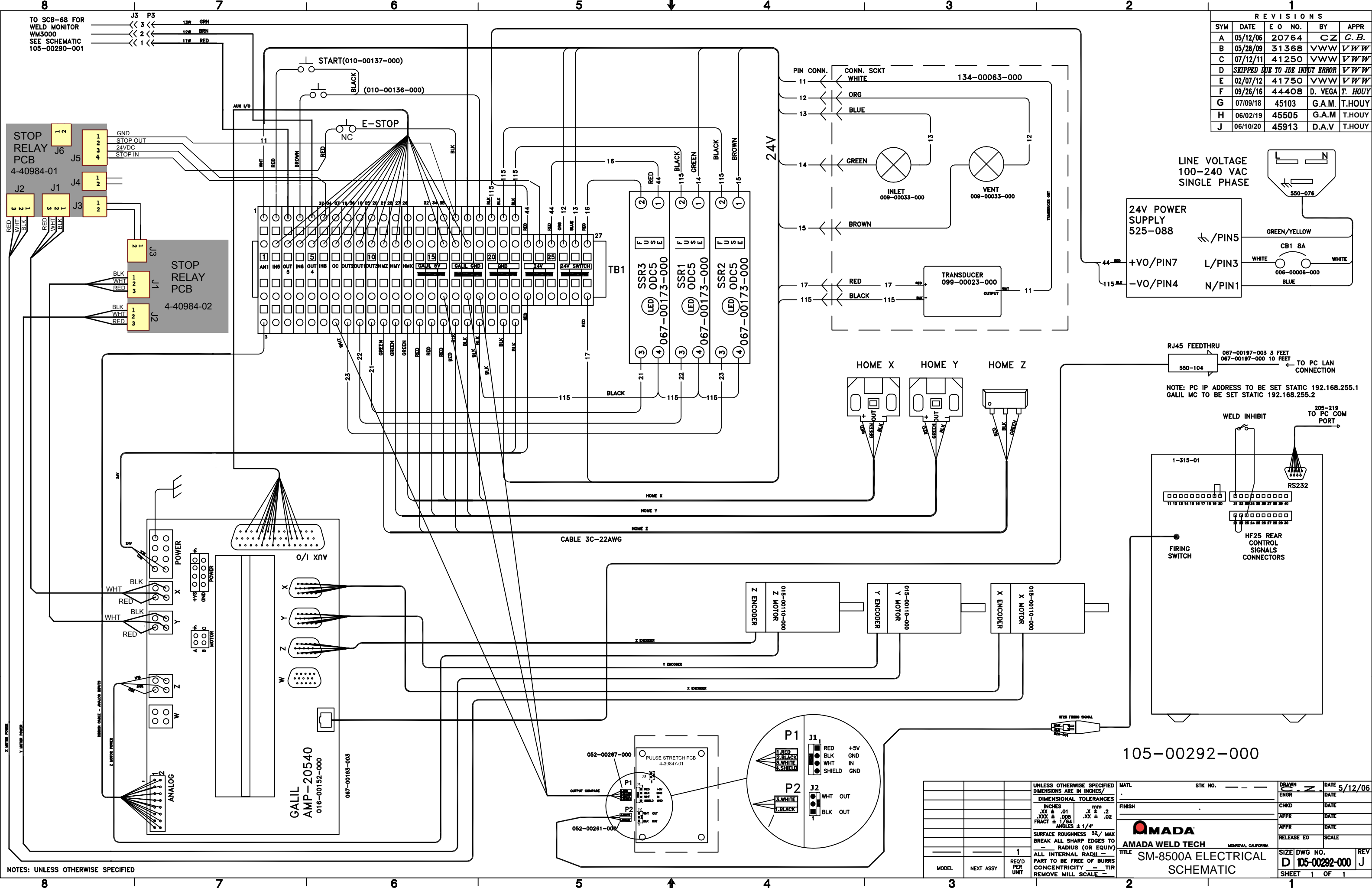

105-00292-000

DIMENSIONAL TOLERANCES		MATERIAL		DRAWN	
INCHES	mm	STK NO.		DATE	5/12/06
.XX ± .01	.X ± .2			ENGR	
.XXX ± .005	.XX ± .02			CHKD	
FRACT ± 1/64	ANGLES ± 1/4°			APPR	
SURFACE ROUGHNESS 32/ MAX				APPR	
BREAK ALL SHARP EDGES TO RADIUS (OR EQUIV)				RELEASE EO	
ALL INTERNAL RADII				SCALE	
PART TO BE FREE OF BURRS				SIZE	DWG NO.
CONCENTRICITY				D	105-00292-000
REMOVE MILL SCALE				SHEET	1 OF 1

NOTES: UNLESS OTHERWISE SPECIFIED