

PRESSURE GAUGE FOR RESISTANCE WELDING MACHINE

# MM-601B

OPERATION MANUAL

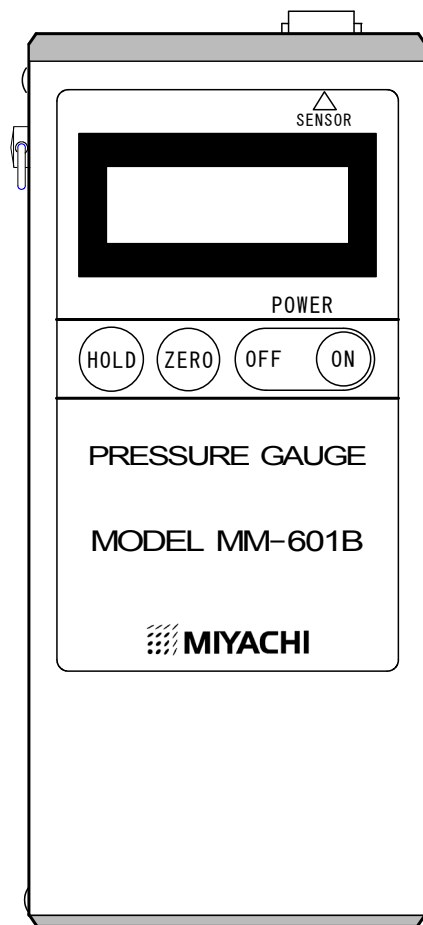

Thank you very much for purchasing the Miyachi Force Gauge MM-601B for resistance welding machines.

- This manual describes the operating procedure and precautions for the MM-601B.
- Please read this manual thoroughly to ensure proper operation of the device. Keep the manual handy for future reference.

---

**MIYACHI CORPORATION**

# Contents

<b>1. Special Notes .....</b>	<b>1-1</b>
(1) Safety Precautions .....	1-1
(2) Precautions for Handling.....	1-4
(3) Before Use .....	1-6
<b>2. Features.....</b>	<b>2-1</b>
<b>3. Packing List.....</b>	<b>3-1</b>
(1) Main Body and Accessories.....	3-1
(2) Options.....	3-1
<b>4. Names and Functions of Each Part .....</b>	<b>4-1</b>
<b>5. Measurement Method.....</b>	<b>5-1</b>
<b>6. Built-In Batteries .....</b>	<b>6-1</b>
(1) Charging .....	6-1
(2) Replacement.....	6-2
<b>7. Specifications.....</b>	<b>7-1</b>
<b>8. Outline Drawing .....</b>	<b>8-1</b>
<b>9. Calibration .....</b>	<b>9-1</b>

## EC Declaration of Conformity

# 1. Special Notes

## (1) Safety Precautions



Prior to use, read these “Safety Precautions” carefully to gain a full understanding of the proper method of use.



- The precautions listed here are designed to ensure safe use and proactively prevent risks and damage to the user and other people. All precautions are critical for safety. Please read them all.
- The hazard signs have the following meanings:

 <b>DANGER</b>
Indicates a high risk of death or serious injury if precautions are not correctly observed.

 <b>WARNING</b>
Indicates a risk of death or serious injury if precautions are not correctly observed.

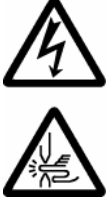
 <b>CAUTION</b>
Indicates operations and practices that may result in personal injury or damage to the equipment if not correctly followed.

	These symbols indicate "prohibition." They are warnings concerning actions out of the scope of the warranty of the product.
	These symbols indicate actions that operators must take.
	Each symbol with a triangle indicates a DANGER, WARNING, or CAUTION to the operator.

 <b>DANGER</b>	
	<b>Do not touch the inside of the device unnecessarily.</b> Burns or electric shock may result. Do not touch the inside of the device other than for maintenance as described in the operation manual.
	<b>Never disassemble, repair or modify the device.</b> These actions can cause electric shock and fire. Do not do anything other than the maintenance described in the operation manual.



# WARNING



**Do not insert your fingers or hands between the electrodes.**

When welding, keep your fingers and hands away from the electrodes.



**Do not touch any welded part or electrode during welding or just after completion of welding.**

The welded parts of a workpiece, electrodes, and the arm are very hot. Do not touch them; burns may result.



**Apply the specified supply voltage.**

Application of a voltage outside the specified range may result in fire or electric shock.



**Use the specified cables and connect them securely.**

Failure to do so or improper connection may result in a fire or electric shock.



**Do not damage connecting cables.**

Do not walk on, twist, or pull on any cable. The power cable and connecting cables may be broken, and that can cause electric shock and fire.



**Do not use a damaged connecting cable or plug.**

A damaged cable or a plug can cause electric shock, short circuits and fire. If any part needs to be repaired or replaced, consult Miyachi or your distributor.



**Stop the operation if any trouble occurs.**

Continuous operation after occurrence of a trouble such as burning smell, abnormal sound, abnormal heat, smoke, etc. can cause electric shock and fire. If such a trouble occurs, immediately consult Miyachi or your distributor.



**Persons with pacemakers must stay clear of the welding machine.**

A person who uses a pacemaker must not approach the welding machine or walk around the welding site while the welding machine is in operation, without being permitted by his/her doctor. The welding machine generates a magnetic field and has effects on the operation of the pacemaker while it is turned on.



**Protective gear must be worn.**

Put on protective gear such as protective gloves, long-sleeve jacket, leather apron, etc. Spatters can burn the skin if they touch the skin.



**Wear protective glasses.**

If you look at the flash directly during welding, your eyes may be damaged. If any surface flash and expulsion gets in your eye, you may lose your eyesight.



# CAUTION



**Remove any dust on the AC adapter and connect it securely.**

Dust and improper connection of the AC adapter may result in heat generation and fire.



**Hold the plug when plugging or unplugging the AC adapter.**

Do NOT pull on the power cord, as this may damage it, resulting in electric shock or fire.



**Unplug the AC adapter from the outlet if the gauge is not to be used for an extended period.**

Leaving the adapter plugged in may degrade the insulation, resulting in electric shock, current leakage, or fire.



**Use proper tools (wire strippers, pressure wire connectors, etc.) for terminal treatment of the connecting cables.**

Do not cut the wire conductor; fire or electric shock may result.



**Use ear protectors.**

Loud noises can damage hearing.



**Keep combustible matter away from the device.**

Spatter may ignite combustible matter. If it is impossible to remove all combustible matter, cover it with non-combustible material.



**Do not cover the device with a blanket, cloth, etc.**

Do not cover the device with a blanket, cloth, etc. while it is in use. The cover may be overheated and burned.



**Keep a fire extinguisher nearby.**

Keep a fire extinguisher in the welding shop in case of fire.



**Maintain and inspect the device periodically.**

Maintain and inspect the device periodically, and repair any damage nearby before starting operation.

## (2) Precautions for Handling

- Do not install the device in the following locations:  
Damp areas (where the humidity is above 90%),  
areas exposed to large amounts of vibration or shock, dusty areas,  
areas near a high noise source,  
areas where water may condense,  
areas where chemicals are handled,  
areas where temperatures are above 40°C or below 0°C,  
areas exposed to direct sunlight, and  
areas that is inclined, insecure, unstable, or weak
- Check the voltage and power frequency before installation.
- Operate the device in accordance with the method described in this operation manual.
- Never supply power to the welding machine while measuring the pressure using this device, as it may cause malfunction or failure.
- Do not apply pressure exceeding the rated pressure of the sensor. Do not apply sudden pressure or impact.
- Do NOT unnecessarily bend the sensor's flexible joint, as this may damage the signal wires.
- Use fully charged batteries. Even if the display does not prompt you to charge the batteries, using batteries that are not fully charged may result in degraded measurement accuracy. (Before using the gauge for the first time, always charge the batteries.)
- Do NOT insert a tool, screw, or anything other than a workpiece between the electrodes, as a malfunction may result.
- Do not insert a screw, coin, etc. into the device, as they may cause malfunction.
- Press switches/buttons carefully by hand. Handling them roughly (using a screwdriver or the tip of pen) may result in a malfunction or failure.
- Press switches/buttons one at a time. Pressing more than one switch/button at a time may result in a malfunction or failure.
- Clean the exterior of the device using a soft, dry cloth or one slightly dampened with water. If the device is very dirty, use diluted neutral detergent or alcohol. Do not use paint thinner, benzine, etc., as they may discolor or deform the device.

- Use only the included or specified chargers.

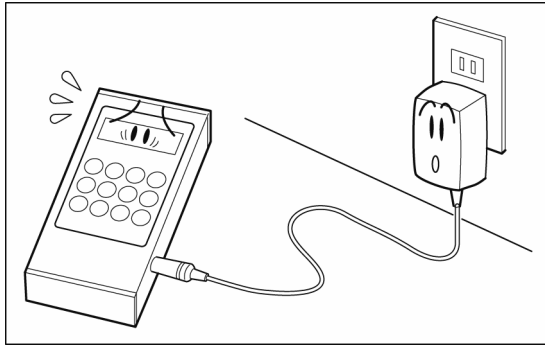

- Do not charge for more than 48 hours.

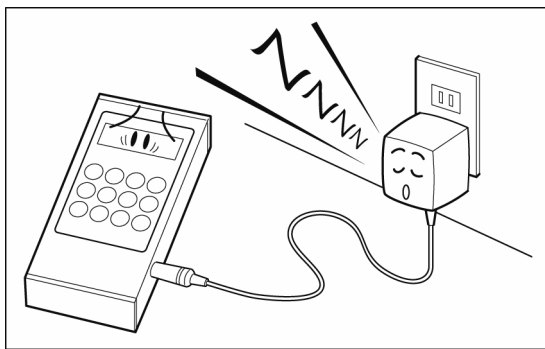

- Do not short-circuit the plug while the charger is connected to an outlet.

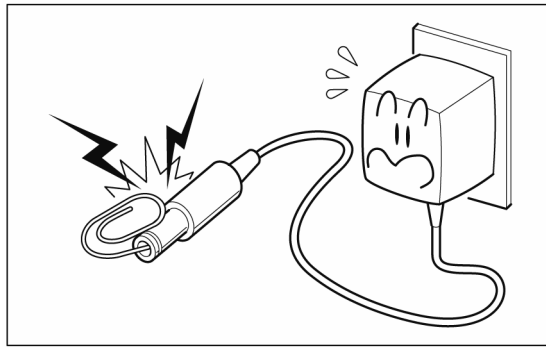

- Do not short-circuit the connector of the charger using a screwdriver, etc.

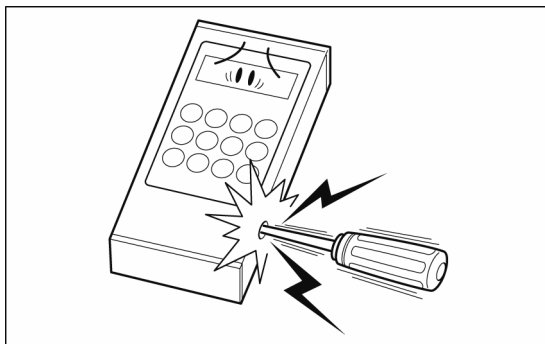

- Do not use the accessory charger for any unit other than the MM-601B.

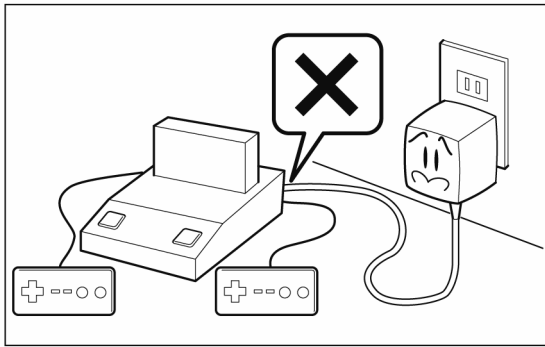

- Remove the charger from the outlet when it is not in use.

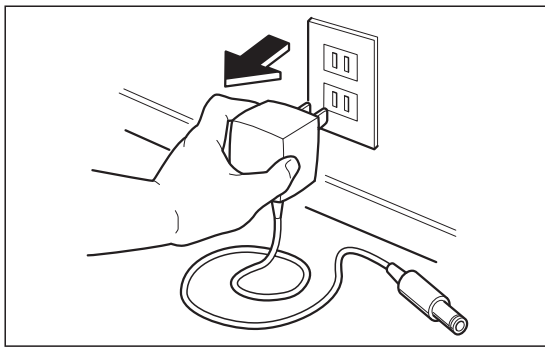

### **(3) Before Use**

Install the attached ferrite core near the connector of the weld-force sensor (optional).

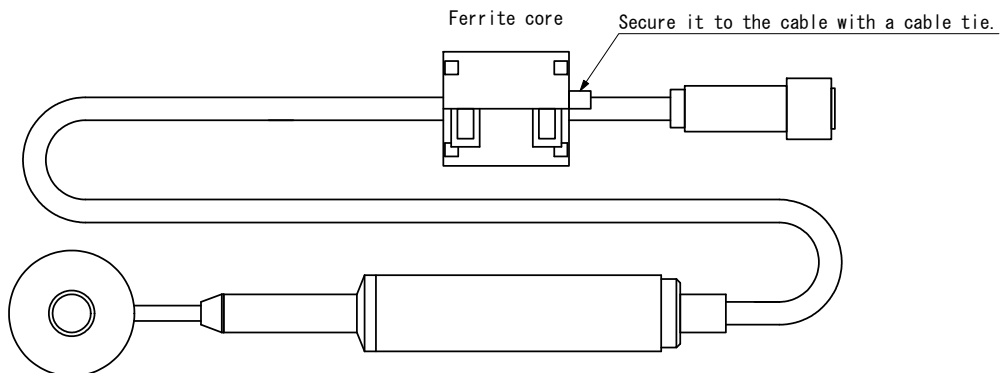



## 2. Features

Model **MM-601B** is a device for measuring the pressure of the electrodes of resistance welding machines that use a load cell (Load converter).

With the optional special sensor, this device can easily measure welding force over a wide range (0.2 kg – 950 kg/0.2 daN – 931 daN).

- Simple operation using a total of four buttons
- Portable and readily usable
- Large, easy-to-read liquid crystal display
- Sheet panel that effectively protects against dust and oil mist

## 3. Packing List

Check the contents of the package. In the case of damaged or missing items, please contact Miyachi Corporation.

### (1) Main Body and Accessories

Item	Model	Item No.	Qty
Main body	MM-601B	-	1
Charger	MM-601B-00-00/01	UN305-7508	1
	MM-601B-00-03*	-	-
Power plug for overseas, C type (MM-601B-00-01 only)	TI-64	1158830	1
Leather case	A3-02945-003	1034458	1
Carrying case	A3-02977	1034768	1
External hold input cable	A-06916-001	1001784	1
Noise filter	ZCAT3035-1330	1023719	1
UB band	UB-100	1040159	1
Operation manual	M0835E	1006875	1

\* The MM-601B-00-03 does not come with a charger. Use a charger with the following specifications.

Output: 7 V $\pm$ 10%, 100 mA minimum

Polarity: Negative Center

### (2) Options

Item	Model	Item No.
Weld force sensor	MA-520-01	1000561
	MA-521-01	1000562
	MA-522-01	1000563

## 4. Names and Functions of Each Part

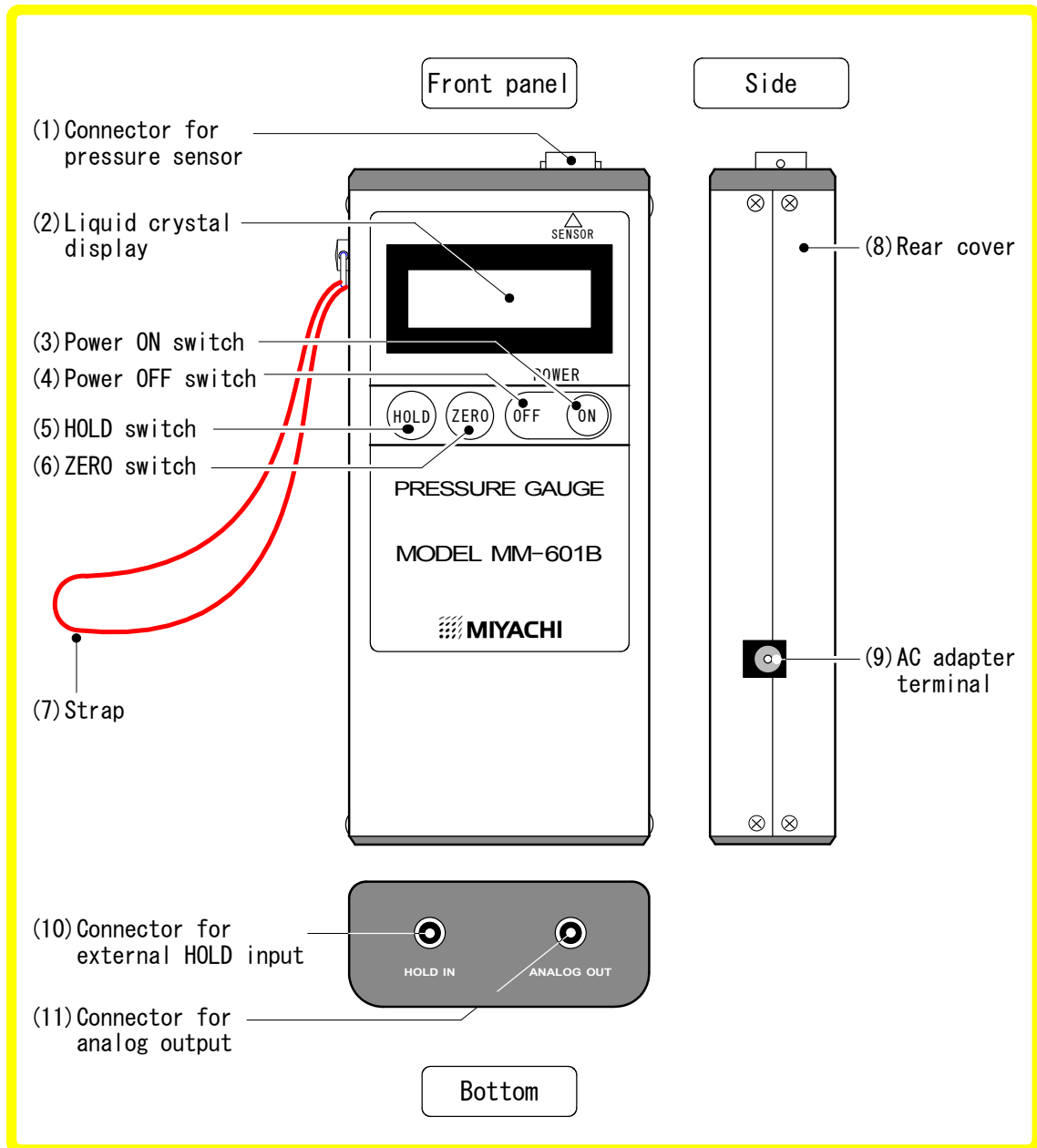

### **(1) Connector for pressure sensor**

Connect the special pressure sensor (optional) suitable for the measurement range.

### **(2) Liquid crystal display**

Shows information including measured values, battery-charging prompt message (refer to p.6-1), and overload message (refer to p.5-2).

### **(3) Power ON switch**

When this switch is pressed, the power for this device is turned on.

#### (4) Power OFF switch

---

When this switch is pressed, the power for this device is turned off.

#### (5) HOLD switch

---

##### To set or cancel the hold mode

Pressing this switch places the LCD display in hold mode, fixing the measured-value display to the value when the switch is pressed.

In hold mode, "H" appears at the top right of the LCD display, with the measured value on the display kept unchanged even if the force changes.

Pressing the hold switch again causes "H" to disappear, canceling the hold mode.

##### Changing the unit

Turn ON the power while pressing and holding this switch; the unit switches from "kg" to "daN" or from "daN" to "kg." (It remains enabled after the power is turned OFF.) After the unit is changed, this switch can be used to set or cancel the hold mode (refer to the above description).

#### (6) ZERO switch

---

Press to set the reading to 0.

#### (7) Strap

---

Hang the strap around your wrist to avoid dropping the gauge.

#### (8) Rear cover

---

Open to replace the batteries.

#### (9) AC adapter terminal

---

While the nickel-hydrogen batteries are being charged or when an external power source is necessary, connect the special AC adapter to this connector.

#### (10) Connector for external HOLD input

---

This connector is used to hold (refer to (5)) a measured value with an external signal. When an external HOLD input cable is connected and a contact input is applied in order to activate a welding-machine timer, etc. through the cable, this device functions as if the HOLD switch were pressed.

The HOLD function can be reset using only the HOLD switch, however.

The plug for external HOLD input is a 3.5-mm mini plug.

#### Warning

The external HOLD input must be a contact input. Never input voltage. If voltage is input, it may not only damage this device but also create a hazard.

## (11) Connector for analog output

This terminal is provided primarily to connect a measuring instrument such as an oscilloscope in order to monitor the applied force.

When a force is applied to the force sensor, a voltage output is provided by the supplied analog output cable. Examining the change in this voltage level enables determination of the timing at which the force achieves equilibrium. This timing serves as a guide when setting the initial force application time (squeeze time).

The output voltage is approximately 4 mV multiplied by the number on the screen regardless of decimal point.

### Example

The number on the screen multiplied by 4 is the output voltage, wherever decimal point is placed, but only when “**kg**” is selected as the unit. Keep in mind that the value is about 3.92 when “**daN**” is selected as the unit.

Reading	Output voltage	Reading	Output voltage
0.01 kg	} → $1 \times 4 = \underline{4 \text{ mV}}$	1.23 kg	} → $123 \times 4 = \underline{492 \text{ mV}}$
0.1 kg		12.3 kg	
1 kg		123 kg	

Note:

Since the sensor offset is included, a maximum of 280 mV is output even when no force is applied. Note also that the rated voltage varies as well due to variations in the rated output.

The measuring instrument to be connected requires an input resistance of 5 kΩ or more.

### Caution

Conduct measurement to ensure that the analog output will not short-circuit. The plug for analog output is a 2.5-mm mini plug.

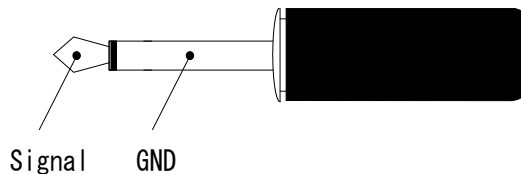

# 5. Measurement Method

## Caution

- Prior to using the tester for the first time, be sure to charge the batteries, which may not be sufficiently charged immediately after purchase. Refer to “Chapter 6, (1) Charging” for the battery-changing procedure.
- Before starting weld-force measurement, be sure to turn off the power to the welding machine, and confirm that it cannot weld. Applying power while the weld force is being measured will damage the device.

### 1. Weld-force-sensor connection

Select an appropriate pressure sensor according to the range of the pressure to be measured, and securely connect it to the weld-force-sensor connector of this device.

### 2. Input/output connection

When using the external HOLD input function, analog output function, etc., connect the appropriate cable for each specific purpose.

When using an external power source, connect the attached AC adapter to the external-power-source connector.

### 3. Turning on the power to the device

When using in the kg indication mode

Press the POWER ON switch to turn on the power to the device.

When using in the daN indication mode

Press the POWER ON switch with the HOLD switch pressed. Press and hold the HOLD switch until “daN MODE” is indicated (for approximately 1 sec).

\* Either indication mode can be selected only at the time the power to the device is turned on.

### 4. Zero setting

Push the ZERO switch to set the indication to zero.

### 5. Preparation of the weld-force sensor

Hold the weld-force sensor so that it is aligned with the welding-machine electrodes. The weld force of the electrodes will be applied vertically to the sensor. (See the figure at right)

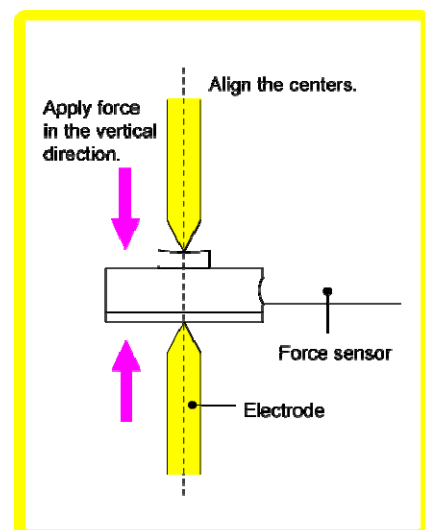

## 6. Welding

---

Perform welding as slowly as possible so that no significant impact is applied to the weld-force sensor.

### Caution

If **“OVER!!”** is indicated and the buzzer sounds intermittently at this time, stop welding immediately, as this indicates excessive weld force.

## 7. Holding and reading the indicated value

---

- 1) When the weld force is fully applied (equilibrium condition), press the HOLD switch to maintain the indicated value.  
If the external HOLD input function is used, the HOLD switch does not need to be pressed.
- 2) When the indicated value is held, **“H”** appears at the upper right of the liquid crystal display.  
(If the device is in the daN indication mode, the letter **“N”** is replaced with **“H.”** It will be replaced with **“N”** again when the hold is reset.)
- 3) Read the indicated value.
- 4) When the HOLD switch is pressed again, the hold is reset.  
When the hold is reset, **“H”** disappears.
- 5) The hold mode can be cancelled only using the hold switch on the panel. Keep this in mind when using an external hold input.

## 8. Peak hold

---

- 1) Press the HOLD switch.  
When the Zero switch is pressed with **“H”** displayed, **“P”** appears and the device is in the peak hold mode.
- 2) When the weld force more than 7% of full scale is applied (refer to table below), the peak hold is performed. When the peak is held, **“P”** is replaced with **“P.”** An additional weld force is applied, the indicated value changes.

<b>MA-520-01</b>	0.7 kg
<b>MA-521-01</b>	7 kg
<b>MA-522-01</b>	70 kg

- 3) Press the HOLD switch to cancel the hold mode.

# 6. Built-In Batteries

## (1) Charging

When the power of the built-in batteries falls to a certain level, “**BATTERY**” starts flashing on the LCD display. (This message flashes seven times, automatically turning OFF the power to the gauge.)

If this message appears, follow the steps described below to charge the batteries.

In addition, keep in mind that you must fully charge the batteries prior to using the **MM-601B** for the first time.

Note that this gauge can be used during charging.

### Precautions

Make sure the batteries are fully charged.

- If the battery power is very low, “**BATTERY**” may not appear on screen. If the batteries are not recharged, their lives will be shortened.
- Even before “**BATTERY**” appears on the screen, using the batteries with a low charge may result in degradation in measurement accuracy.

(1) Firmly plug the included AC adapter into the AC adapter terminal.

(2) Plug the AC adapter into the outlet for a specified voltage.

### WARNING

Always use the AC adapter on a specified power line.

Using it under other power conditions may not only cause a malfunction, but also result in fire or electric shock.

(3) Approximately 15 hours are required to fully charge the batteries with the gauge power turned OFF.

### Precautions

Do NOT charge the batteries for more than 48 hours. Excessive charging will shorten the service life of the batteries. Further, be sure to charge the batteries at an ambient temperature of 35°C or lower.



## (2) Replacement

The built-in batteries will last three to five years under normal usage conditions, and can be charged approximately 500 times for repeated use. (The service life varies depending on the frequency of use. The battery life will be shortened if stored for extended periods without being used.)

The batteries need replacing if the operation time is significantly shorter after normal charging. Follow the steps described below to replace the batteries.

### Precautions

Always use nickel-hydrogen batteries. Further, replace all four batteries with the same type of batteries at the same time.

Do NOT mix new and old batteries or different types of batteries. Do NOT use batteries other than nickel-hydrogen batteries.

### Battery

Item name	Item No.	Model	Specification
Nickel-hydrogen battery	1169000	210AAHCB-UC4	AA battery (UM-3) IEC/JIS model No.: HR6 Voltage: 1.2 V Capacity: 2050 mAh

- (1) Remove the four screws from the rear cover.
- (2) Open the rear cover.
- (3) Remove all four nickel-hydrogen batteries from the battery holder in the gauge.
- (4) Install four new nickel-hydrogen batteries, making sure the positive (+) and negative (-) ends of each battery face in the proper direction.
- (5) Replace the rear cover.
- (6) Tighten the four screws of the rear cover.

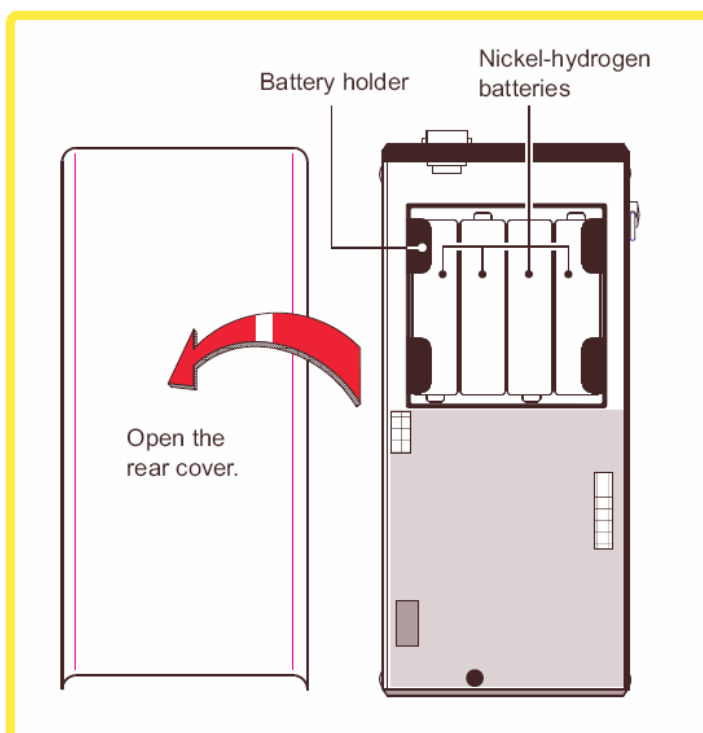

### ⚠ WARNING

Do NOT short-circuit between positive and negative terminals; fire may result.



# 8. Outline Drawing

(Unit: mm)

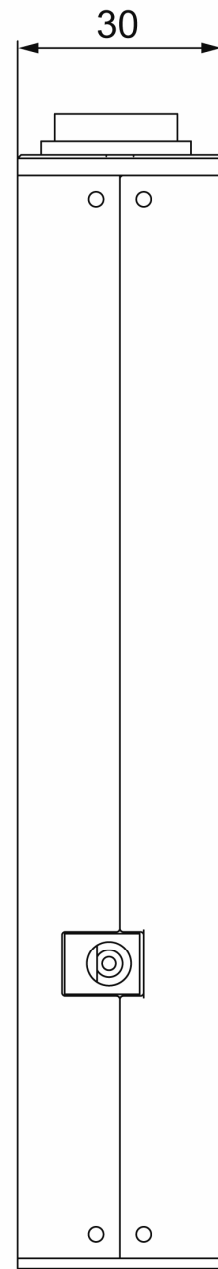
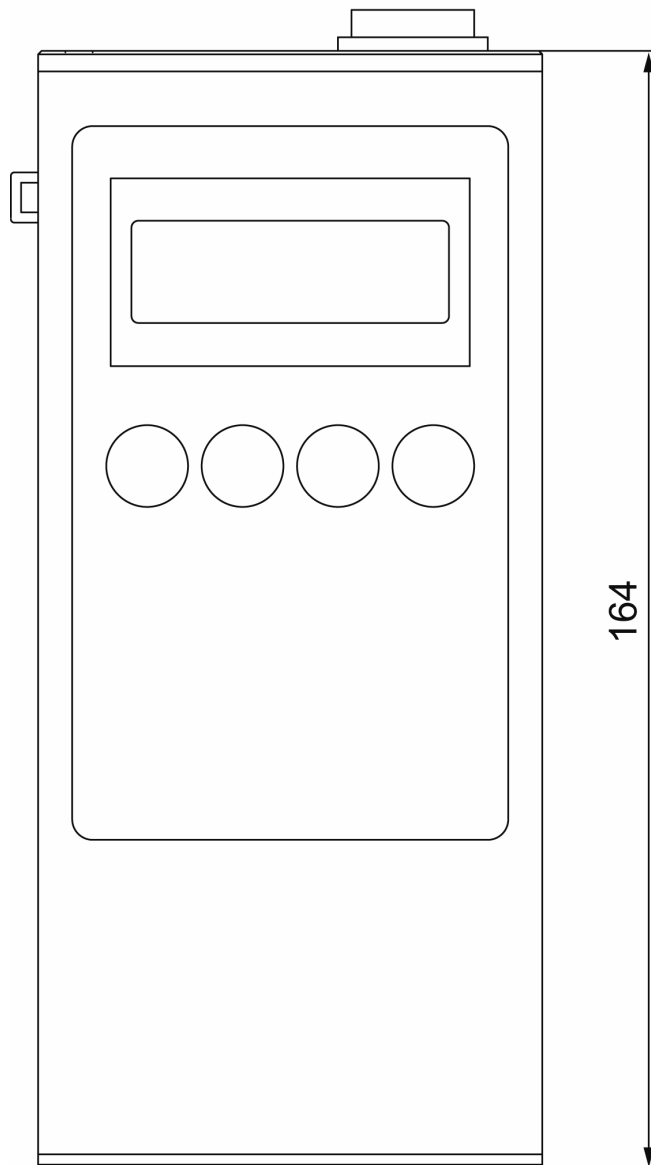
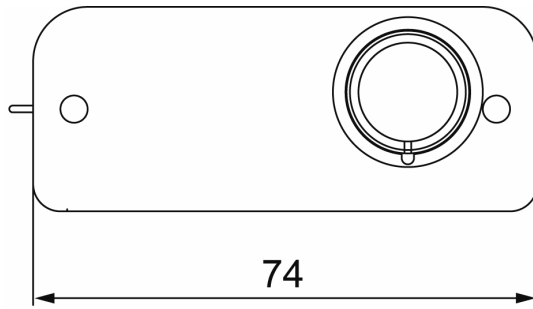

## **9. Calibration**

To maintain the performance of the **MM-601B**, it is necessary to calibrate it periodically. The calibration is carried out at our factory. Send us your weld-force sensor with the **MM-601B** for calibration. Because the conditions of degradation of the **MM-601B** differ depending on the operation environment, it is necessary to calibrate the **MM-601B** and the weld-force sensor together.

Contact Miyachi Corp. for details of calibration.



**MIYACHI CORPORATION**

**EC Declaration of Conformity**

**The company/manufacturer: MIYACHI CORPORATION**  
**95-3, Futatsuka, Noda-City, 278-0016 JAPAN**

**Herewith declares in his own sole responsibility conformity of the product**

**Designation: Pressure Gauge for Resistance**  
**Welding Machine**

**Types/Serial Number, etc.: MM-601B**

**With applicable regulations below**

**EC Directive: Low Voltage Directive 2006/95/EC**  
**EMC Directive 2004/108/EC**

**Harmonized European/International Standards applied:**

**IEC 60204-1:2009, EN 61010-1:2010 (3rd) , IEC 61326-1 Ed. 2.0:2012 (b),**  
**EN-50178:1998, IEC 61000-6-2:2005, EN-55011:2009+A1:2010,**

**Importer Distributor in EU:**  
(please place distributor/importer stamp here)

**MIYACHI EUROPE CORPORATION**  
Lindberghstrasse 1, D-82178 Puchheim, GERMANY  
Tel: + 49 8983 9403 - 1

**Division:**

**MIYACHI CORPORATION**

Noda-City/Japan 2012-12-18  
Place and Date

*Mitsuaki Aoyama*  
Mitsuaki Aoyama / Quality guarantee general manager  
Name/Signature/Position

*Note: This Declaration certifies conformity with the above mentioned Directive(s), but gives no assurances of properties within the meaning of the Law concerning product liability and GPSG. It becomes invalid if any technical or other modification are carried out without manufacturers consent.*