



***USER MANUAL
CAPACITIVE DISCHARGE POWER SUPPLY
AND
OPPOSED ELECTRODE PROJECTION
WELDING SYSTEM***

AMADA WELD TECH INC.

1820 S. Myrtle Ave

Monrovia, CA 91016

REVISION RECORD

Revision	EO	Date	Basis of Revision
D	43229	12/14	See ECO for description
E	45833	05/20	See ECO for description
F	46265	03/21	Add CD-P12000A + Updates
G	46292	04/21	See ECO for description
H	47206	01/24	Update KN-200A Images + Manual Title

TABLE OF CONTENTS

<u>Section</u>	<u>Description</u>	<u>Page</u>
1.0	<i>Standard System Specifications</i>	4
2.0	<i>General Safety Warning</i>	5
3.0	<i>Installation and Hook-Up</i>	6
	3.1 Unpacking	6
	3.2 Positioning	6
	3.3 Electrical and Gas Service Requirements	6
	3.3.1 Electrical Service	6
	3.3.2 Gas Service	6
4.0	<i>CD-P Capacitive Discharge Supply Operation</i>	7
	4.1 General Information	7
	4.2 Power Supply Transformer and I/O Connections	8
	4.2.1 Power Input Panel (CD-P3000A –CD-P9000A)	8
	4.2.2 Power Input Panel (CD-P12000A)	8
	4.2.3 Transformer & Weld Head Connections	9
	4.2.4 Main PCB and I/O access	12
	4.2.5 Charge delay dipswitch SW1	12
	4.2.6 I/O Features	13
	4.3 Timing Diagram	15
5.0	<i>KN-200A with SS-100A Operation</i>	16
	5.1 Opposed Electrode Projection Weld Head	16
	5.2 Weld Head to Weld Transformer Connections	16
	5.3 Solid State Weld Controller (SS-100A)	16
	5.4 Welding System Start-up	18
	5.5 Welding	18
	5.6 Timed Pneumatic Ejector System	20
6.0	<i>System Maintenance</i>	21
	6.1 Weld Head and Connections	21
	6.1.1 Weld Head	21
	6.1.2 Electrode Holder Alignment & Co-Planarity	21
	6.1.3 Weld Transformer Connections	23
	6.1.4 Welding Electrodes	23
	6.2 Capacitive Discharge Power Supply	23
	6.3 Solid State Weld Controller (SS-100A)	23

1.0 STANDARD SYSTEM SPECIFICATIONS

Weld Head

- Forge Force Range: Adjustable between 120 – 1200 pounds of force (single range) and between 120-1200 / 2800 / 4000 pounds of force (wide range)
- Stroke: 1.875 inches
- Electrode Holders: Quick-change (1" dia or 2" dia standard sizes)
- Alignment: Zero Alignment Die set
- Kinetic Expander: Expansion > 0.25 inches (6.4 mm)
- Die Set Design: Zero weld zone flexure
- Device Ejection: Automatic (optional)

Weld Controller

- Approach Time: Adjustable from 50 ms to 3 seconds
- Forge Time: Adjustable from 50 ms to 3 seconds
- Hold Time: Adjustable from 50 ms to 3 seconds
- Weld Initiate Circuit: Automatic
- Locking Regulators: Adjustable from 10 PSI to 100 PSI
- Cycle Status: Visual illuminated indicators
- Input Power Requirements 120 VAC, 50/60 Hz, Single Phase, 5 Ampere
- Input Compressed Air 20 – 120 PSI (clean/dry supply)

Capacitor Discharge Power Supply

- Energy Stored: Continuously adjustable from;
CD-P3000A: 30 – 3,000 joules, CD-P6000A: 60 – 6,000 joules,
CD-P9000A: 90 – 9,000 joules, and CD-P12000A: 200 – 12,000 joules
CD-A1000A: 10 – 999 joules
- Repetition Rate Limitation: > 10,000 joules: Maximum 4 welds/minute
≤ 10,000 joules: Only limited by recharge rate.
- Remote Control: Remote control of Energy, Weld and Ready/Wait functions
- Energy Display: Digital display; weld energy directly in 10 joule increments for CD-P power supplies and 1 joule increments for the CD-A1000A power supply.
- Weld Pulse: 5 to 28 milliseconds (depending upon welding load)
- Capacitor Bank: CD-P3000A: 9,300 µf, CD-P6000A: 18,600 µf,
CD-P9000A: 27,900 µF, and CD-P12000A: 37,200 µf
CD-A1000A: 13,600 µf

Capacitive Discharge Welding System

- Capacitor Voltage: CD-P Models: 40 – 800 VDC with equalizer circuit
CD-A1000A Model: 400VDC
- Circuitry: All solid state - charge and discharge
- Control Circuit Protection: Zener-referenced closed loop circuit
- Firing Circuit Protection: Discharge inhibited until charge is verified
- Cooling: Air cooled, internally filtered, with thermal protection
- Input Power Requirements: CD-P Power Supplies: 208/240/480 VAC (jumper selectable), 50/60 Hz, 1Ø
CD-A1000A Power Supply: 120 – 220 VAC 50/60 Hz, 1Ø
- Charging Amperes: Adjustable from 10 – 30 amperes
- Weld Transformer: High efficiency matched weld transformer

2.0 GENERAL SAFETY WARNING

Throughout this equipment lethal voltages exist. It is of the utmost importance that the service or test personnel be completely familiar with all aspects of this equipment and operation. During any diagnostic test involving motion, be sure hands are clear of all moving parts.



Disposal

Properly handle and dispose of used materials.
For the disposal of electronic waste please contact AMADA WELD TECH.

3.0 INSTALLATION AND HOOK-UP

3.1 Unpacking

Upon receipt of the equipment, remove all packing materials and visually inspect the equipment for obvious signs of shipping damage. Report any damage immediately to the carrier. The carrier claims agent must file a report with the user which can then be forwarded to:

**AMADA WELD TECH INC.
1820 S. Myrtle Ave.
Monrovia, CA 01017**

The Service Department will advise the customer on the actions to be taken to repair or replace damaged equipment.

3.2 Positioning

When positioning equipment, observe the following requirements:

- Allow a minimum of 18 inches (457 cm) all around the CD-P Capacitive Discharge Power Supply (units rated 3000 Joules and higher) for service accessibility.
- Position the Capacitive Discharge Power Supply (units 3,000 joules and over) within six (6) feet (1.5 m) of the rear or side of the welding transformer.

3.3 Electrical and Gases Service Requirements

3.3.1 ELECTRICAL SERVICE

For Capacitive Discharge Power Supplies rated @ 3,000 Joules and higher, the electrical service is as follows: 208/240/480 VAC (jumper selectable), 50/60 Hz, Single Phase, 30 Ampere (Note: input voltage is specified at the time of manufacture. The input voltage is easily changeable after the unit is in the field).

For CD-A1000A Capacitive Discharge Power Supplies rated @ 1,000 Joules, the electrical service is as follows: 120 – 220 VAC, 50/60 Hz, Single Phase, 15 Ampere.

For Solid State Pneumatic/Electronic Weld Controller, the electrical service is as follows: 120VAC, 50/60 Hz, Single Phase, 5 Ampere.

3.3.2 GAS SERVICE (required for KN-200A weld head if ordered)

Compressed air (or other gas) input to the Solid State Pneumatic/Electronic Weld Controller is as follows: Clean, Dry (Gas) @ 20 – 120 PSI through 3/8" O.D. tube fitting.

4.0 CD-P Capacitive Discharge Supply Operation

4.1 General Information

The welding power supply is a Capacitor Discharge design, configured in standard power ratings of 1,000 joules (CD-A1000A), 3,000 joules (CD-P3000A), 6,000 joules (CD-P6000A), 9,000 joules (CD-P9000A) and 12,000 joules (CD-P12000A). The power supply takes low input voltage and stores it in capacitor storage banks. Discharge is affected directly from the capacitor banks, and is unaffected by any drop or surge in the input voltage. Important advantages result from this design. Weld stability is assured, as the output energy is independent of the main AC power input and the weld pulse is of short duration, with concentrated high energy. The weld pulse localizes heat in the weld zone, precluding the detrimental effects of excessive heat build-up in adjoining areas.

Diagnostic circuitry monitors the status of the power supply and performs automatic weld monitoring, preventing weld firing if the power level differs from the adjustable set point. Automatic shutdown of the air-cooled supply occurs if the heat warning lights are ignored and an overheating situation should occur.

The magnetic core of the computer-designed welding transformer is automatically reset after each weld to prevent saturation at all energy levels.

Stored energy is continuously adjustable via a pendant with a 10-turn potentiometer control for 3,000 joule systems and higher. For CD-A1000A power supplies energy is digitally programmable via the front panel keys. The operation of the CD-A1000A is described in the CD-A1000A operation manual.

The amount of stored energy is displayed in Watt seconds (or joules) via 3-digit digital display.

1. A convenient socket in the front of the supply allows easy connection to weld head trigger switch: for 3,000 joule systems and higher.
2. Remote energy display
3. "Ready" and "Wait" lamps and/or interlocks

4.2 Power Supply, Transformer and I/O connections

4.2.1 Power Supply Input panel – CD-P3000A / CD-P6000A / CD-P9000A

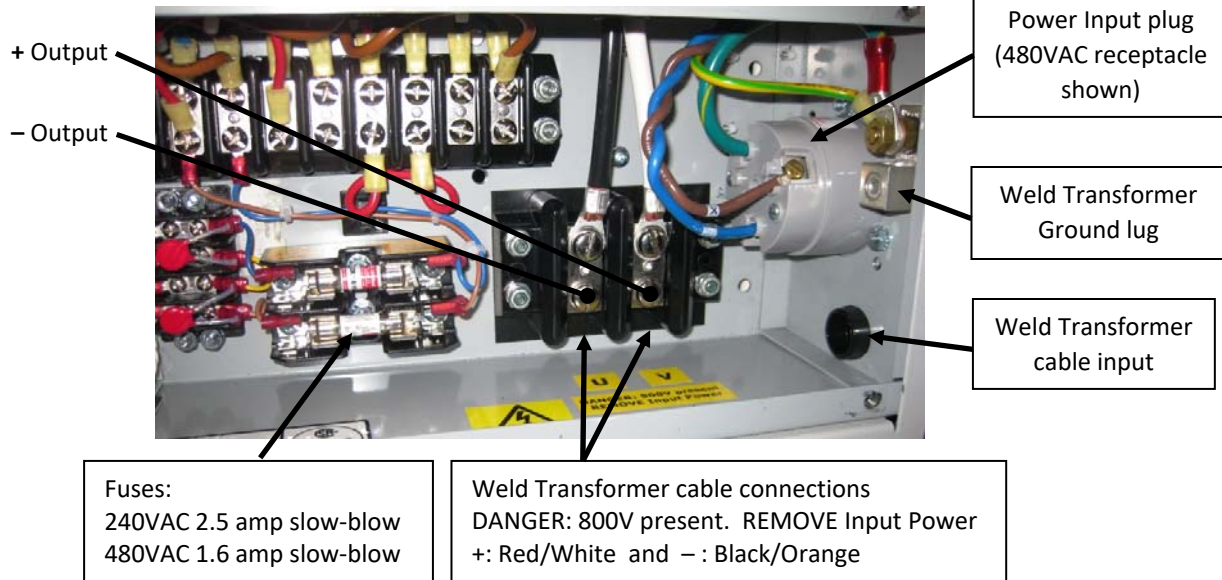

4.2.2 Power Supply Input panel – CD-P12000A

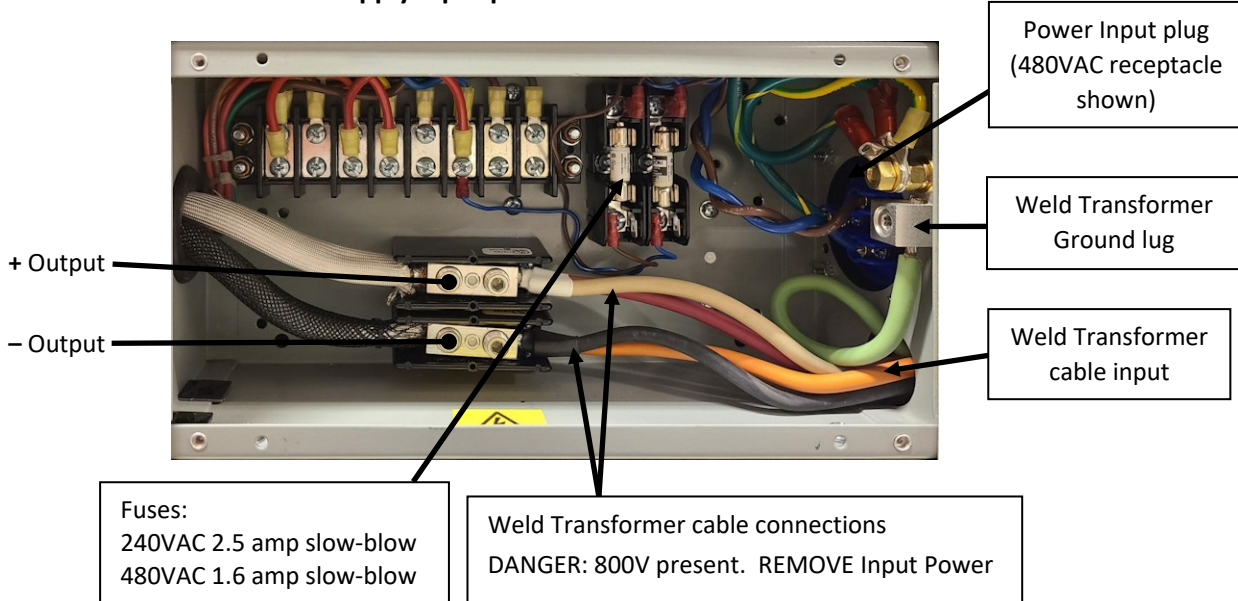

4.2.3 Transformer & Weld Head Connections

There are a number of ways the CD-P System can be wired, depending on what type of output pulse is needed and the physical orientation of the components.

The example shown on the right is an alternate connected system (offset mounted transformer) with a KN-200A Weld Head, CD-P12000A Capacitor Discharge Power Supply (not shown in the picture) and a CD-P9000A / CD-P12000A Transformer.



CD-P Standard Hook-Up
(shown with KN-200A Weld Head)

Note: Connections for the CD-P3000A and CD-P6000A are basically the same, with a slight difference in terminal location.

In all cases, the polarity of the connections will determine the polarity of output pulse:

Positive Output Pulse: 

Negative Output Pulse: 

CD-P9000A / CD-P12000A Transformer (4-41862-01) Connections:

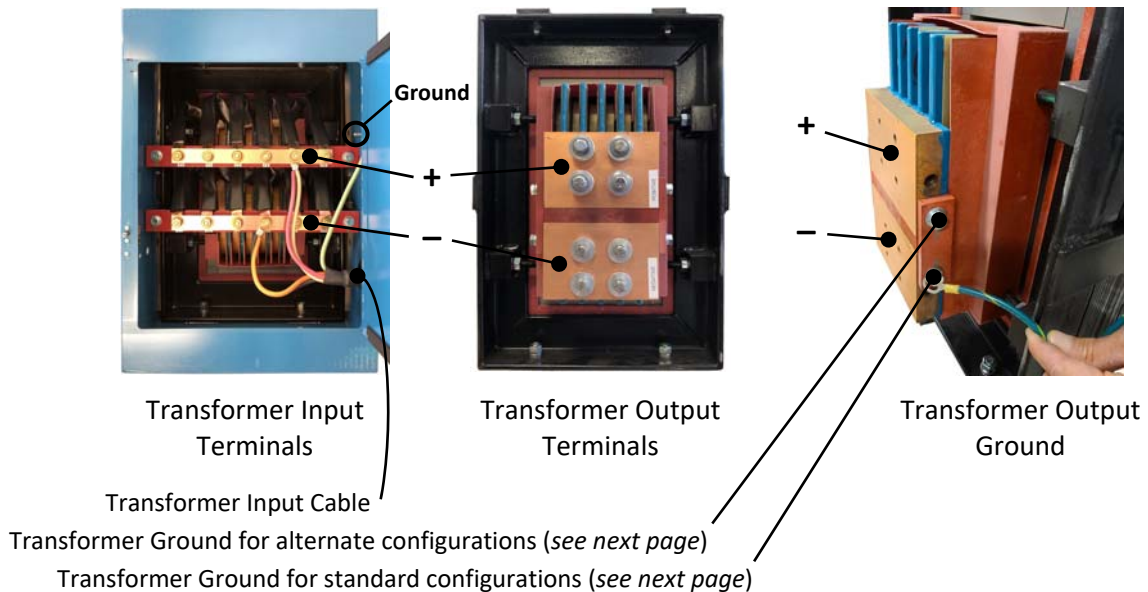

Note: The ground wire should always be connected to the Transformer Output Terminal that is connected to the Weld Head ground.

CD-P3000A / CD-P6000A Transformer (4-40301-01) Connections:

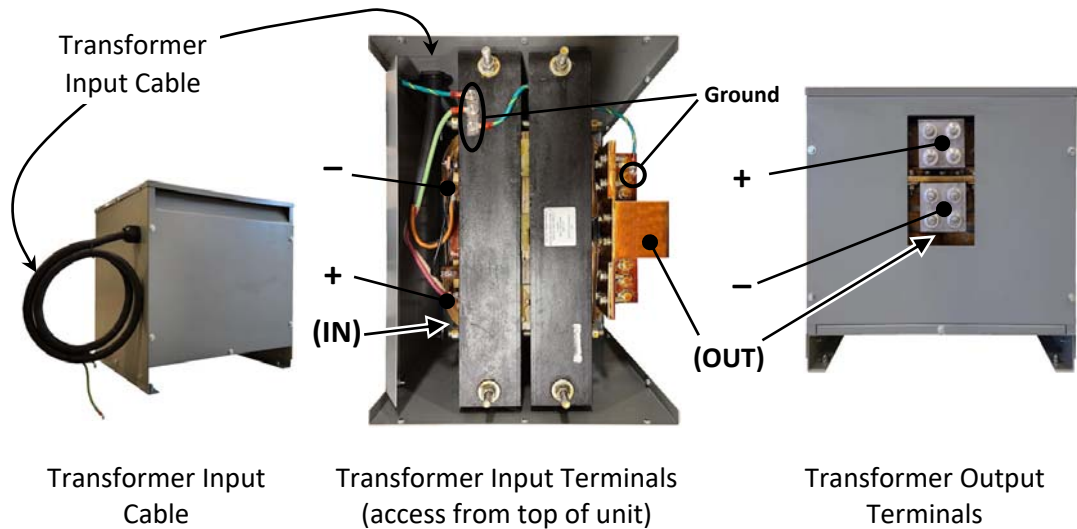

Note: The ground wire should always be connected to the Transformer Output Terminal that is connected to the Weld Head ground.

Standard Hook-up (Offset Mounting). The connection diagram shown below is wired in the standard configuration with the CD-P9000A / CD-P12000A Transformer (same polarity rules apply for the CD-P3000A / CD-P6000A Transformer). This configuration connects the positive of the CD-P Power Supply to the positive rail of the transformer input. The positive terminal of the transformer output connects to the positive terminal on the Weld Head. When connected in this configuration you will get a positive output pulse.

Special attention must be given to the system ground. The Weld Head will be grounded to the workstation. An additional ground wire also needs to be connected between the Transformer Output terminal and the Transformer Chassis. Use one of the existing bolts on the transformer to make a solid ground connection. (*Note: scrape paint away under the bolt in order to secure a proper ground*).

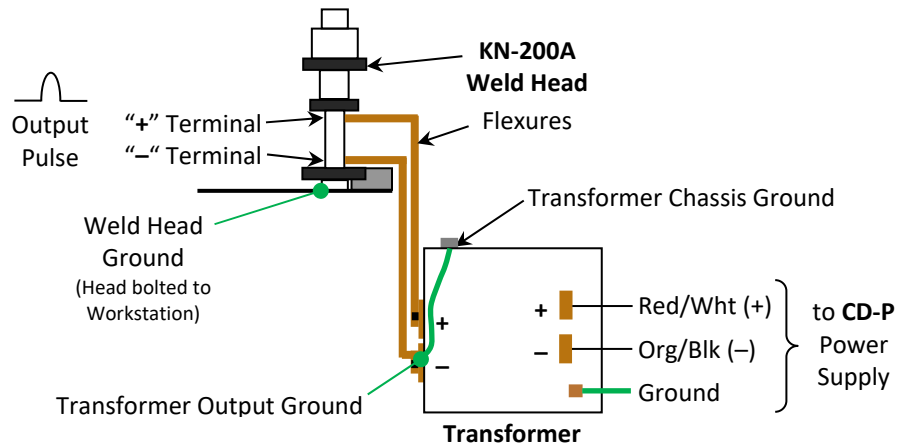

Alternate Hook-up (Under Head Mounting). The connection diagram shown below is wired in the alternate configuration with the CD-P9000A / CD-P12000A Transformer (same polarity rules apply for the CD-P3000A / CD-P6000A Transformer). Since the transformer is oriented 180° from the standard configuration, this reverses the transformer connections; which connects the positive terminal of the Weld Head to the negative terminal of the transformer. In order to get a positive output pulse, the output of the CD-P Power Supply needs to be connected in reverse, as shown below. Like the Standard configuration above, special attention must be given to the system ground.

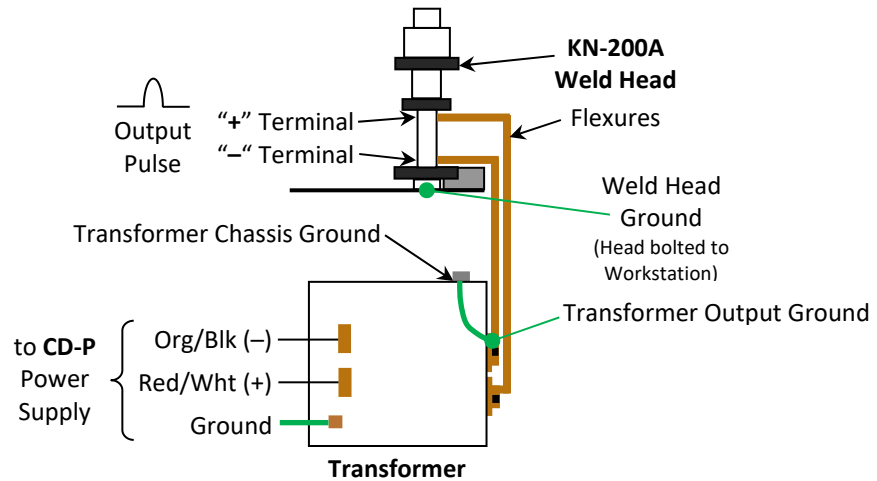

Note: If the desire is to produce a negative output pulse, simply reverse the CD-P connections on the Transformer Input.

4.2.4 Main PCB and I/O access

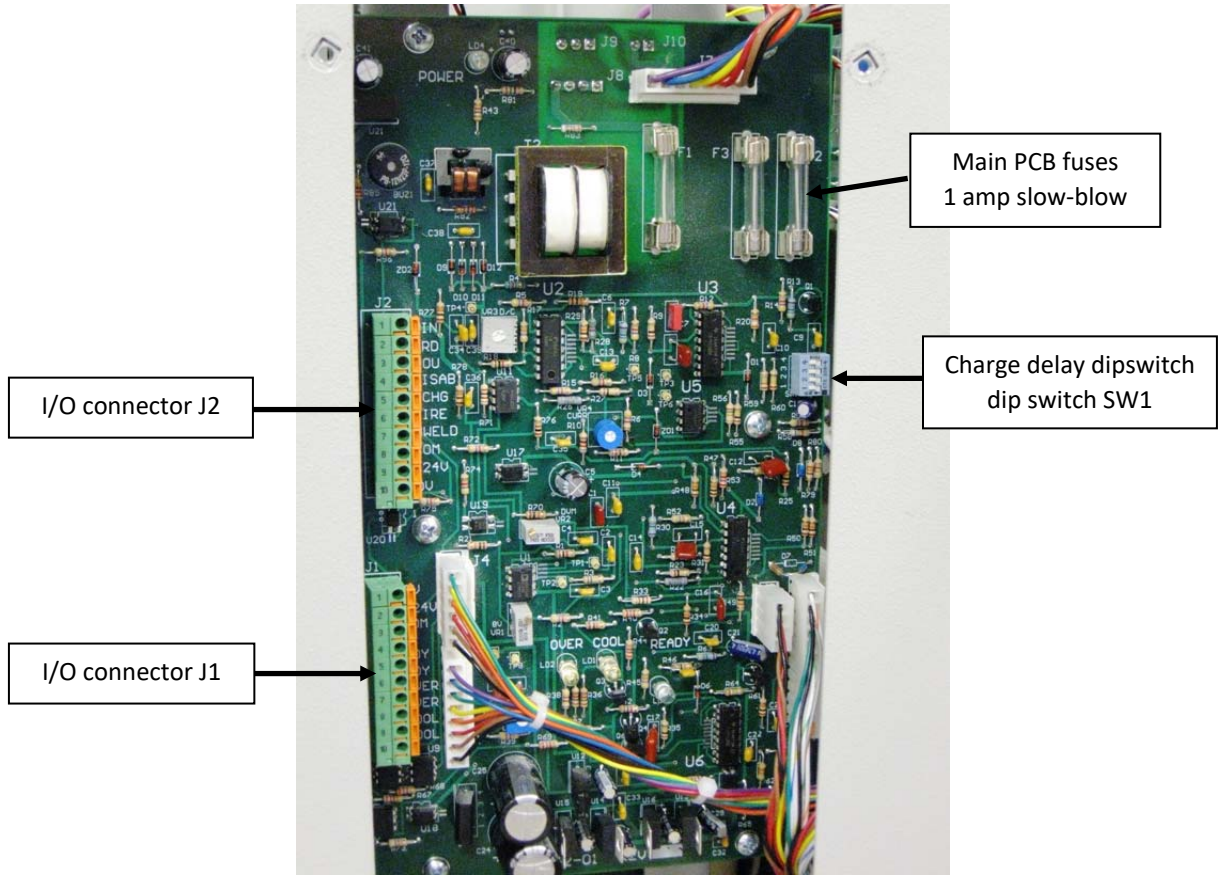

4.2.5 Charge delay dipswitch SW1

Dipswitch allows user to select the time delay from end of weld pulse to the start of capacitor charge.

Note: Charge is delayed while firing switch is held low

SW1	Never charge	2.5 sec delay	1.3 sec delay	0.8 sec delay	0.41 sec delay	0.12 sec delay
Position 4	O	X	O	O	X	O
Position 3	O	O	X	O	X	O
Position 2	O	O	O	X	X	O
Position 1	O	O	O	O	O	X

NOTE: X = ON, O = OFF

Factory default: Position 2 "ON" (0.8 seconds)

4.2.6 I/O features:

Main PCB I/O connector J1

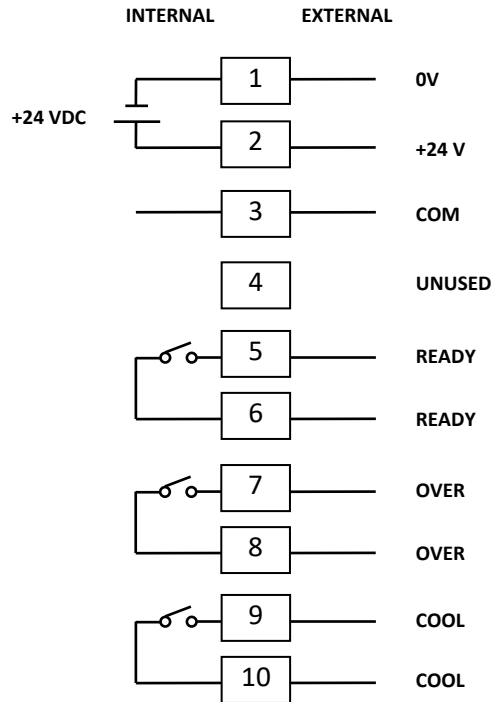

Main PCB connector J1		Description of pins
Pin 1	0V	24 VDC ground
Pin 2	+24V	+24VDC supply output, 75 mA max., can be used for I/O input use ONLY
Pin 3	COM	I/O common
Pin 4		<i>unused</i>
Pin 5	RDY	Relay output, closed = unit is READY
Pin 6	RDY	
Pin 7	OVER	Relay output, closed = OVERHEAT, unit inoperable until cooled down
Pin 8	OVER	
Pin 9	COOL	Relay output, closed = APPROACHING OVERHEAT
Pin 10	COOL	

Main PCB I/O connector J2

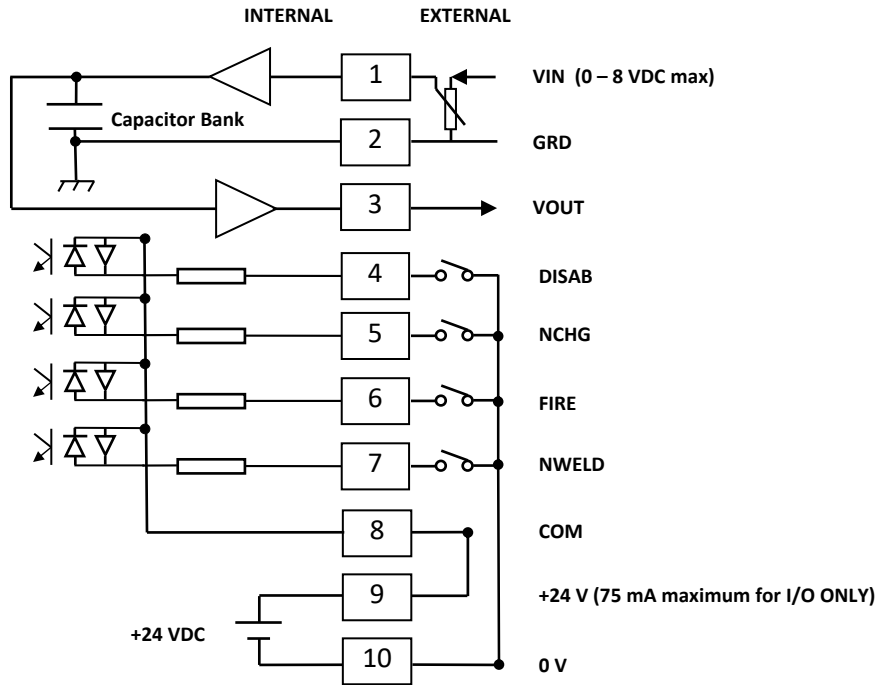

Main PCB connector J2		Description
Pin 1	VIN	Capacitor control voltage in, 0 - 8 VDC max (ref: GRD)
Pin 2	GRD	Chassis ground
Pin 3	VOUT	Capacitor bank voltage output, 0 - 8 VDC max. (ref: GRD)
Pin 4	DISAB	Disable operation and firing, will discharge capacitor bank, used with COM
Pin 5	NCHG	No charge input, charge disable input, used with COM
Pin 6	FIRE	fire unit input, used with COM
Pin 7	NWELD	Disable weld input, used with COM
Pin 8	COM	I/O common, used with input pins 4 – 7; set 0 V for +24 V operation; set +24 V for 0 V operation;
Pin 9	+24V	+24 VDC supply output, 75 mA max., can be used for I/O input use ONLY
Pin 10	0V	24 VDC ground

4.3 Timing Diagram:

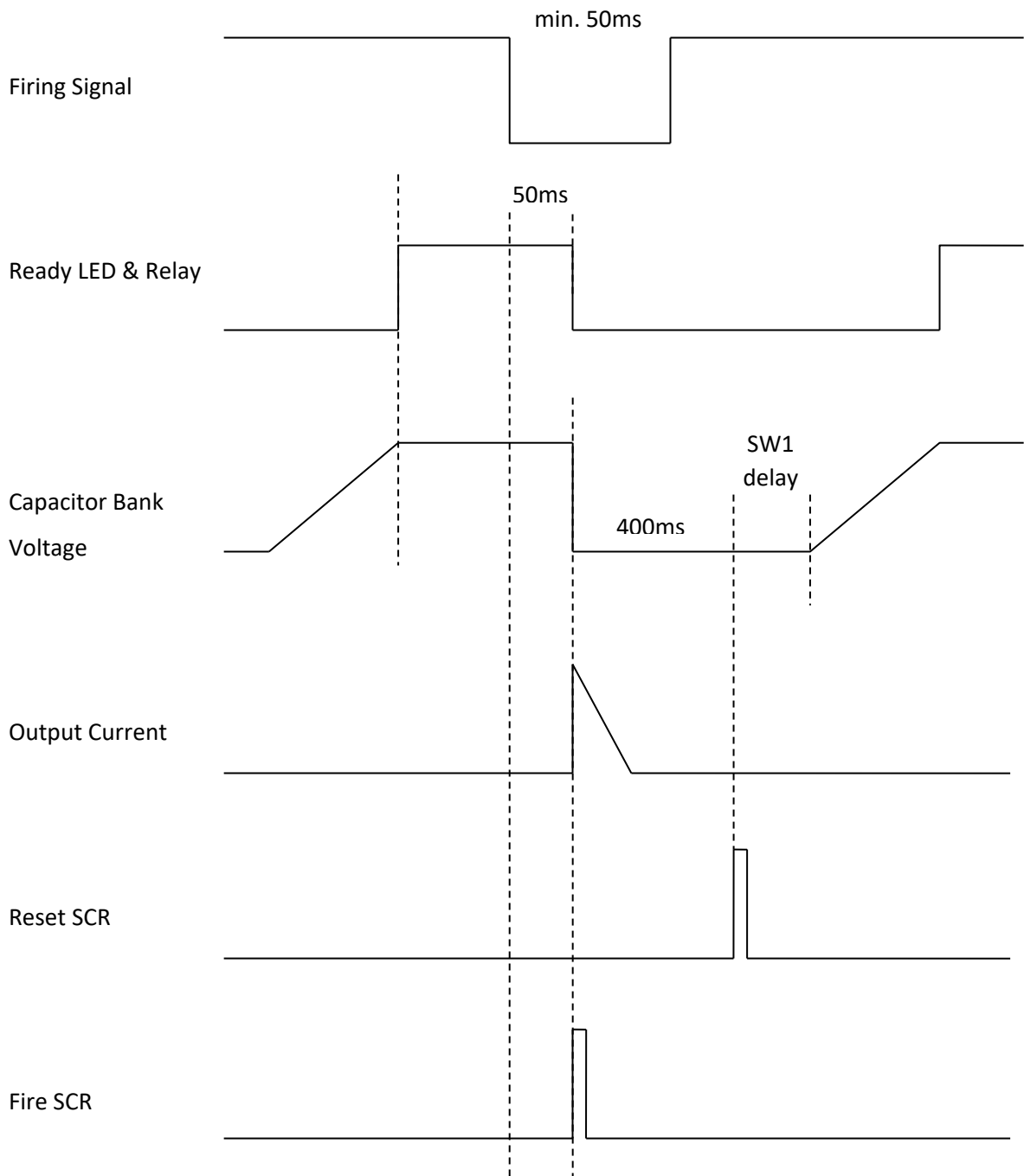

5.0 KN-200A with SS-100A OPERATION

5.1 Opposed Electrode Projection Weld Head

The weld head is very simple in design. It consists of two opposing electrodes mounted in a precision die set. The electrodes are custom machined to accept only the parts to be welded. The die set is connected to an air cylinder via a special low hysteresis compression coupling. This coupling also provides fast weld follow-up, allowing complete fusion of metal without weld splatter.

The weld head has the capability of welding with accuracy better than +/- 0.001 (25 micron) with a repeatability of better than 99%.

"Quick Change" electrode holders provide easy installation or change-over of the custom machined electrodes. The electrodes should be carefully cleaned prior to installation. Use very fine emery cloth (400 grit) backed by a flat metal surface to polish the electrodes. Use minimal pressure and the flat backing to maintain the parallelism between the electrode surfaces. Finish polishing the electrodes with Crocus Cloth.

NEVER USE A FILE OR COARSE GRIT EMERY CLOTH TO CLEAN THE ELECTRODES. THE RESULTING GROOVES CAN BECOME DISCHARGE POINTS ON THE SURFACE OF THE ELECTRODES. THE PARTS TO BE WELDED MAY FUSE TO THE ELECTRODE INSTEAD OF TO EACH OTHER.

After 4,000 to 5,000 welds, the electrodes should be removed and inspected. If necessary, the electrodes may require dressing in a lathe. Refer to the Maintenance Section of this manual for details.

5.2 Weld Head to Weld Transformer Connections

The welding head must be connected to the secondary of the welding transformer. Capacitor Discharge welding applications require the use of the AMADA WELD TECH designed copper buss bar assembly. The buss bar assembly is supplied factory assembled, and requires very little set-up by the machine operator. It is imperative that the contact points on this buss bar assembly be kept thoroughly clean as contaminants might impair the transfer of power to the welding electrodes. Refer to the maintenance section of this manual for buss bar cleaning instructions. Refer to Section 4.2.3 for connection details.

5.3 Solid State Weld Controller (SS-100A)

Solid state design provides precise weld parameter control and repeatability independent of the system operating environment.

The welding process is initiated by depressing two palm buttons simultaneously. This assures that the machine operator's hands are clear of the weld area, thus eliminating possible injury. Once the palm buttons have been pressed, the weld controller applies low pressure air to the weld head cylinder, closing the electrodes. The force (Approach Pressure) with which the electrodes close can be independently adjusted to avoid damage to the parts being welded. When the electrodes have closed, the controller automatically applies high air pressure to the

weld head cylinder. At this point, the operator can release the palm buttons and the welding sequence will continue automatically. Pressure continues to increase until the force at the electrodes reaches the pre-set Forge Pressure (independently adjustable). The Capacitive Discharge Power Supply can now discharge. An adjustable Hold sequence follows the Weld action. Low pressure air is then applied to the weld head cylinder to open the electrodes. When the electrodes are fully opened, the welded device can be removed from the electrodes.

Single range systems manufactured after July 1996 may come equipped with an internal pneumatic Eject System as an option. This Eject System is tied to the timing sequence of the weld controller, and allows the welded device to be automatically ejected from the electrodes onto a discharge chute. From there, the welded device is transferred to a carrier for removal from the weld suite. See Section 6.7 of this manual for operation of this feature.

Resistance welding applications require that Approach and Forge pressure settings be adjusted for the specific weld application. An initiation lead pair must be connected to the associated power supply to trigger a weld pulse when the forge pressure has been reached. The Solid State Weld Controller is used in conjunction with the welding head to allow for pressure adjustments, and to trigger the weld pulse. Controls for the Solid State Weld Controller are as follows:

APPROACH: The Approach control is used to set the speed of the weld head descent prior to the Forge cycle. Typically, the Approach Time is set to 1.5 seconds, the midrange of the control. The Approach Pressure is set for a smooth descent, usually within 8-10 PSI. The Approach Lamp indicates when the system is in the Approach mode.

FORGE: The Forge control is used to set the squeeze of the weld head prior to the weld cycle. Typically, the Forge Time is set to 1.5 seconds, the midrange of the control. The Forge Pressure is set for the correct force for the specific part to be welded, usually starting from a midrange point, about 50 PSI. The Forge Lamp indicates when the system is in the Forge mode.

HOLD: The Hold control is used to set the time delay after the weld has taken place, prior to the ascent of the weld head cylinder. Typically, the Hold Time is set to 1.5 seconds, the midrange of the control. The Hold Lamp indicates when the system is in the Hold mode.

WELD / DRESS FUNCTION: The Weld / Dress switch is used for the control of the weld system. **In the Dress position, the weld head is activated via the foot switch for setup purposes only, and is not to be used in production situations.** **WARNING:** Keep hands clear from weld head moving parts while activating the footswitch to avoid severe injury to self and others. During use in the Dress mode, the Capacitive Discharge Power Supply is inhibited from discharging. In the Weld mode, the system is actuated via the two-hand palm button control, and the Power Supply is fully ready for welding.

FORGE RANGE: This switch is used to set the maximum forge pressure allowable for the weld process. Wide Range systems utilize all three switch positions (low/med/high) to give the maximum pressure range for the system. In Single range systems, the switch is factory disabled.

5.4 Welding System Start-Up

Before applying power to the welding system, be sure the following items are checked and or cleared. It is assumed that the system is in its final operating position, and the weld head has been aligned.

1. Check to see that there are no parts or other obstructions between the weld head electrodes.
2. Verify the electrical service input requirements are met, and all power connections are plugged in.
3. Verify proper airline pressure, and that connections are tight.
4. Check to see that the Capacitive Discharge Power Supply main power switch is OFF, and the power adjustment knob on the remote power console is turned fully counter clockwise.
5. Check to see that the Main Power switch for the Weld Controller is OFF.

5.5 Welding

As mentioned before, resistance welding applications require that pressure and time settings be adjusted for each specific welding application. Trial welds on "sample" parts are recommended to establish the most optimal welding parameters prior to a production run. Visual inspection under a microscope and or leak testing are two possible methods of verifying the integrity of the hermetic seal.

Prior to shipment from the factory, test welds are performed on the system using customer supplied sample parts, or Benchmark Test Sample parts. The weld parameters used during the system testing (referred to as Weld Schedules) are kept on file and are available, if requested, to aid the user in establishing the correct weld requirements.

The following is a generalized sequence of procedures for welding operations utilizing the optional **Capacitive Discharge Opposed Electrode Projection Welding System**.

1. Apply power to the Weld Controller by turning the Main Power switch ON.
2. Push the Weld / Dress switch to the Dress position.
3. Set the Forge Pressure to approximately 50 PSI.
4. Set the Approach Pressure to approximately 10 PSI.
5. Set the Approach Time to approximately 1.5 seconds.
6. Activate the foot switch to bring the electrodes together. Adjust the Approach Time and Pressure to set a smooth descent of the weld head. Keep hands clear of moving parts.
7. Apply power to the Capacitive Discharge Power Supply by turning the Main Power switch ON.
8. Push the Weld Controller Weld / Dress switch to the Weld position.
9. Adjust the output control of the Power Supply to the appropriate level by turning the dial on the remote power console.



WARNING: To avoid possible injury to operator or damage to associated equipment, always begin by setting the output control of the welding power at the lowest possible energy level for a specific operation. Some power supplies generate very high levels of energy. Applying excessive weld energy to a weld head may result in the explosive splattering of molten material, which may injure the operator or cause damage to the weld head and / or the enclosure.

10. Position parts to be welded in the electrodes. The cover (lid or cap) is placed upside down in the lower electrode. The header (base) is then placed onto the cover. Fixturing may be required for very small parts.



WARNING: Never use the dress function of the controller to position parts in the electrode area. Approach pressures can be set to levels which can cause severe injury to the machine operator and also may damage the welding electrodes.

11. Initiate the welding sequence by pressing both operator palm buttons simultaneously. Hold the buttons until approximately 1 second after the electrodes have come together, then release the palm buttons.
12. If so equipped, when welding is complete, at the apex of the weld heads ascent, the Eject Switch is activated, and the welded part is pushed up out of the lower electrode. In some instances, the operator may be required to remove the part from the Eject Chute to a separate handling container.

5.6 Timed Pneumatic Ejector System

For systems equipped with the timed pneumatic eject system, all controls for the eject operation are factory pre-set. Re-calibration of the ejector may need to occur if a different weld schedule is required for the welding process.

To re-calibrate the ejector, follow these steps:

- 1.** With correct weld schedule developed, install a welded part into the lower electrode.
- 2.** Place the Weld Remote Console Weld/No Weld Switch to the No Weld position, and cycle the weld head.
- 3.** When the weld head starts its ascent, adjust the Eject Delay control on Timer #4 in the Solid State Weld Controller to inhibit the eject pin from plunging up for approximately a 1/2 second delay.
- 4.** Adjust the Eject Time control (Timer #4) in the weld controller to hold the ejector pin in the plunge up position for approximately one second. This should enable the part to fall into the discharge chute.

The adjustment of the two controls may need to be experimented with to obtain the optimal operation.

6.0 SYSTEM MAINTENANCE

6.1 Weld Head and Connections

Problems with weld head operations can usually be traced to associated equipment such as the air supply (insufficient pressure), weld controller, or the weld power supply.

6.1.1 WELD HEAD

The weld head bearing shafts should be cleaned every time a visual inspection reveals foreign matter on the shafts. The shafts should be wiped clean with a clean cloth and then lubricated with a light silicone lubricant. Be sure to wipe off any excess. As a routine check, all hardware on the head should be checked for tightness every six (6) months.

6.1.2 ELECTRODE HOLDER ALIGNMENT AND COPLANARITY

The electrode holders must be properly aligned to ensure that top and bottom electrode holders are concentric and coplanar with each other.

KN-200A weld head mechanical alignment and flatness calibration procedure
Calibration Tools needed to perform KN-200A weld head mechanical calibration:

1" Diameter Electrode holder alignment kit 139-00005-000

Flatness tool 3 pcs, P/N 112-02364-000 (1 pair to be used)

Flatness, 1 pc to be used for alignment to mate with 112-02364-001

Top to bottom electrode holder alignment tool, P/N 112-02364-001



2" Diameter Electrode holder alignment kit

Flatness tool 1 pair, P/N 112-04243-003

Top to bottom electrode holder alignment tool, P/N 112-0243-002



Steps in performing KN-200A weld head mechanical alignment and flatness calibration:

1. Before you start adjusting flatness, check the flatness of the electrodes. If the flatness of the electrodes needs adjusting, use the flatness tool until the flatness is within 0.0002" across the entire surface, then continue with these steps.
2. Turn weld power OFF.
3. Set all SS-100A timers to 1.5 sec.
4. Set SS-100A approach pressure to 8 PSI.
5. Set SS-100A Forge pressure to 20 PSI.
6. Put a carbon paper or pressure print paper between the electrodes.
7. Press palm switches to perform a weld cycle.
8. If carbon pressure print result is still not acceptable after using electrodes or flatness tool which are within 0.0002" the lower bus bar has to be shimmed.
9. Remove lower electrode holder.
10. Loosen 2 shoulder bolts holding the lower bus bar.
11. Add shims under the bus bar which need to be raised.



WARNING: DO NOT ADD SHIMS UNDER THE ELECTRODE HOLDER THIS WILL COMPROMISE THE CONTACT AREA BETWEEN THE ELECTRODE HOLDER AND THE BUS BAR.

12. Tighten lower bus bar shoulder bolts.
13. Loosely install lower electrode holder.
14. Using alignment tool on the bottom electrode, align bottom electrode holder with reference to the top electrode holder by Turning Forge pressure regulator to zero and manually lowering the top portion of the weld head.
15. Once top and bottom electrodes are aligned, tighten lower electrode holder screws.
16. Turn forge pressure back to 20 PSI (weld head will move up).
17. Put a carbon paper or pressure print paper between the electrodes.
18. Press palm switches to perform a weld cycle.
19. Perform carbon pressure print test, if results are not acceptable repeat steps 9 to 21.

6.1.3 WELD TRANSFORMER CONNECTIONS

At least every year, it is important to disassemble the copper bussing to clean any tarnish found at the connection points. Remove any dirt particles with a very fine emery cloth (320 - 400 grit). Do not use coarse grit emery cloth or a file, as these can nick or pit the copper surface of the buss bar. Use Thiourea in a mild hydrochloric solution (Tarnex) and a clean paper towel to remove any remaining contaminants. Rinse with clean water, preferably distilled.

CAUTION: After cleaning the copper buss bars, do not touch the clean surfaces with your bare hands. Oils and dirt from such contact can impair the power transfer performance of the assembly.

6.1.4 WELDING ELECTRODES

The welding electrodes should be dressed at regular intervals when they become worn. The purpose of dressing the electrodes is to clean the surfaces of pits and nicks while maintaining 0.0002" parallelism across the weld face of the electrode. The following procedures are performed when dressing the electrodes.

1. Chuck the electrodes in a lathe and use an appropriate cutting tool to remove 0.002 – 0.003 in. (0.05 – 0.08 mm) of material. Check weld face parallelism must be 0.0002" across the electrode weld face
2. Re-cut a radius or break sharp edge where appropriate on the top electrode to avoid crimping damage caused by sharp surface angles.
3. Use a flat metal or glass backing plate behind very fine emery cloth followed by crocus cloth to finish polishing the electrodes.
4. Remove any contaminants using Thiourea in a solution of mild hydrochloric acid (Tarnex) and a clean paper towel.

6.2 Capacitive Discharge Power Supply

Once every six (6) months, the discharge capacitors in the unit should be checked for loose hardware connections. If the hardware is left loose, it could cause premature failure.

6.3 Solid State Weld Controller (SS-100A)

The pneumatic / electronic weld controller is virtually maintenance free. Should you incur any problems or malfunctions with the unit, please contact the service department for assistance.

AMADA WELD TECH INC.

<http://www.amadaweldtech.com>

AMADA WELD TECH INC.

1820 South Myrtle Ave., Monrovia, CA 91016, U.S.A.
TEL. +1-626-303-5676 FAX, +1-626-358-8048
<http://www.amadaweldtech.com>

AMADA WELD TECH CO., LTD.

200, Ishida, Isehara-shi, Kanagawa 259-1196, Japan

AMADA WELD TECH KOREA CO., LTD.

28, Dongtanhana 1-gil, Hwaseong-si, Gyeonggi-do, 18423, Korea
TEL. +82-31-8015-6810 FAX. +82-31-8003-5995

AMADA WELD TECH SHANGHAI CO., LTD.

Unit 401, A206(C8), No. 77, Hongcao Road, Xuhui District, Shanghai, China
TEL. +86-21-6448-6000 FAX. +86-21-6448-6550

AMADA WELD TECH GmbH

Lindberghstrasse 1, DE-82178 Puchheim, Germany
TEL. +49-89-839403-0 FAX. +49-89-839403-68

AMADA WELD TECH TAIWAN CO., LTD.

Rm. 5, 2F., No. 9, Dehui St., Zhongshan Dist., Taipei 10461, Taiwan (R.O.C.)
TEL. +886-2-2585-0161 FAX. +886-2-2585-0162

AMADA VIETNAM CO., LTD.

469 Ha Huy Tap Road, Yen Vien, Gia Lam, Ha Noi, Vietnam
TEL. +84-4-6261-4583 FAX. +84-4-6261-4584

AMADA (THAILAND) CO., LTD.

Asia Industrial Estate Suvarnabhumi (AIES) 88/41 Moo 4, Khlongsuan, Bangbo, Samutprakarn 10560, Thailand
TEL. +66 2170-5900 FAX. +66 2170-5909

AMADA WELD TECH INDIA PVT. LTD.

G-A Ground Floor, 5C-409, 5th Cross, Kammanahalli Main Road, HRBR Layout, Kalyan Nagar, Bengaluru, - 560043, India
TEL. +91-80-4092-1749 FAX. +91-80-4091-0592

AMADA WELD TECH LTDA.

Av. Tamboré, 965/973, Salas P22e F11, bairro Tamboré, 06460-000-Barueri-SP, Brazil
TEL. +55-11-4193-1187

AMADA WELD TECH INC.

1820 South Myrtle Ave., Monrovia, CA 91016, U.S.A.

TEL. +1-626-303-5676 FAX. +1-626-358-8048